

INSTALLATION AND MAINTENANCE MANUAL FOR 2-WAY FLANGED BALL VALVES

INTRODUCTION

The BI-TORQ InstruPak IS-2PF series uses the ED-211F 150# flanged ball valve. The split body design provides easy replacement of gaskets, seals and seats without any special tools. The floating ball design allows the ball to move horizontally in the ball cavity with line pressure, creating a bubble-tight shut-off and allowing the valve to be used in either flow direction or for dead-end service.

1. USE

1.1 The life of the valve can be maximized if valve use is within the stated pressure, temperature and corrosion ranges.

2. MANUAL OPERATION

2.1 Valve in open position: handle is parallel (in-line) with the valve or pipeline.

2.2 Valve in closed position: handle is perpendicular (crossed) to the valve or pipeline.

3. AUTOMATED OPERATION

3.1 Valves with actuators should be checked for stem alignment. A mounting kit is required for automating ED-211F ball valves. Make sure that all drive couplers are properly placed on the valve stem and fully engaged in the actuator before automating.

4. GENERAL INFORMATION FOR ON-SITE INSTALLATION

4.1 The valve may be fitted in any position in the pipeline. For automated operation, BI-TORQ does recommend that the valve and actuator be installed vertically in case of valve leakage, although this is not necessary for proper operation of the valve.

4.2 To prevent damage to the seats and ball surface, the pipeline must be flushed so that it is free of dirt, burrs and welding residues before installing the valve.

5. DISSASSEMBLING AND CLEANING THE VALVE

NOTE: If the valve has an electric or pneumatic actuator in place, remove the actuator before proceeding.

CAUTION: Ball valves can trap fluids in the ball cavity when it is in the closed position. If the valve has been used with hazardous media, it must be decontaminated before disassembly or handling.

WARNING: All persons involved in the removal or disassembly of the valve should wear protective gear such as eye and face protection, gloves, etc.

5.1 Relieve the line pressure.

5.2 Place the valve in the half-open position and flush the line to remove any hazardous material(s) from the valve.

6. REPLACING THE THRUST WASHER, PACKING AND SEATS

NOTE: The ED-211F series valve is designed with Belleville washers for automatic wear compensation. If there are signs of leakage from the stem, it is time to replace the stem packing and thrust washer.

NOTE: If the valve has an electric or pneumatic actuator, remove the actuator before proceeding.

6.1 STEM PACKING

a. Before replacing the thrust washer and the packing, the pipeline must be depressurized.

b. Remove flange bolts and nuts, then lift the valve from line. Care should be taken to avoid scratching or damaging gaskets. **NOTE:** The ED-211F series valves generally are heavy, so ensure that the valve is adequately supported before removing it from the line.

c. Loosen the handle nut and remove handle, retainer ring and stop plate. (**IMPORTANT:** On 2-1/2" through 4" sizes, the bonnet bolts must also be removed.)

d. The stem packing is placed in the center recess of the top cover. A tap to the bottom of the stem packing will get the packing out of the recess.

e. On the 2-1/2" through 4" sizes, the top cover gasket can be found between the contacting surface of the top cover and the valve body.

6.2 SEATS AND END CAP GASKETS

NOTE: In order to replace the end cap gaskets, the end caps must be removed. BI-TORQ recommends that seats and gaskets be replaced at the same time.

a. Remove body bolt nuts on all three end caps and blank (back) plate.

b. Once the end caps are removed, the ball can be removed from the valve body. Caution should be taken to avoid

INSTALLATION AND MAINTENANCE MANUAL FOR 2-WAY FLANGED BALL VALVES

damaging the ball.

c. Replace all seats, body seals and gaskets at this time. NOTE: The valve may be assembled and operated dry without lubricant. However, a light lubricant will aid in the assembly and reduce initial operating torque. Ensure that the lubricant is acceptable with the intended line fluid.

7. REASSEMBLY

7.1 Install seats on the end caps so that the seats are in the same orientation as the removed seats (i.e., with the curvature facing the ball).

7.2 Install gaskets on the end caps. The end cap gaskets should fit on the outer diameter of the end cap.

7.3 Replace the bottom bushing in the valve cavity.

7.4 Place ball on top of the bushing in the center of the valve body cavity.

7.5 Carefully re-attach the end caps to the valve body. Hand tighten the bolts. Do not tighten with the wrench at this time.

7.6 Tighten the bolts in a star-shaped pattern to the torques specified in TABLE 1.

7.7 Install the stem packing in the center recess of the top cover.

7.8 2-1/2" through 4" only: Install top cover gasket.

7.9 2-1/2" through 4" only: Place the top cover back on the valve. Tighten in a star shaped pattern in accordance with the torque values in TABLE 1.

7.10 Cycle the valve slowly to gradually build to a full quarter turn. By cycling slowly, the seat curvature will create a permanent seal shape against the ball. CAUTION: A fast turning motion at before the seats are shaped properly might cut the seals before they have a chance to form a proper seal.

7.11 If possible, test valve before placing back into line. If not properly secured, the valve can separate from the pressure source, resulting in potential injury. IMPORTANT: Always join the valve to companion flanges of the same pressure rating of the valve and secure with a full set of flange bolts.

**CHART 1.1:
Bill of Materials**

PART #	NAME	MATERIAL	QTY
1	BODY	ASTM A351 GR CF8M	1
2	ENDS	ASTM A351 GR CF8M	2
3	BALL	ASTM A351 GR CF8M	1
4	SEAT	TFE	2
5	BODY SEAL	TFE	2
6	STEM SEAL	TFE	1
7	STEM PACKING	TFE	1
8	THRUST WASHER	50% PTFE + 50% SS POWDER	1
9	O-RING	VITON	1
10	BELLEVILLE WASHER	304SS	2
11	LOCK WASHER	304SS	1
12	STEM NUT	304SS	1
13	HANDLE	304SS	1

**TABLE 1:
End Cap Bolt Torques**

VALVE SIZE	BODY BOLT TORQUE (IN LBS)
1/2"	90
3/4"	90
1"	120
1-1/4"	190
1-1/2"	225
2"	310
2-1/2"	380
3"	420
4"	460

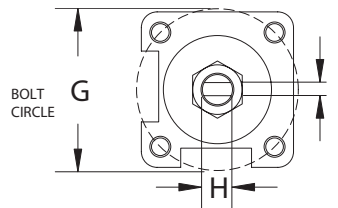
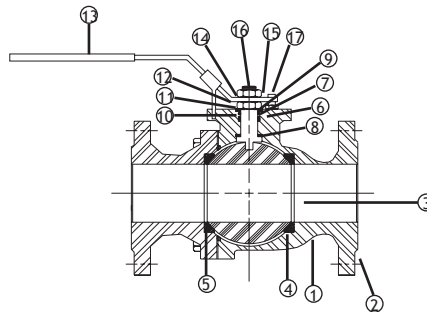

To order a complete new valve, please refer to BI-TORQ price list for InstruPak valve replacement.



COMPLETE VALVE PART NUMBER: ED-211F-***

***=VALVE SIZE (005=1/2", 007=3/4", 010=1", 012=1-1/4", 015=1-1/2", 020=2", 025=2-1/2", 030=3", 040=4")

¹ COMPLETE REPAIR KIT INCLUDES SEATS, SEALS AND O-RINGS