

SPRING RETURN "DEADMAN" HANDLES



Spring return "deadman" handles will help you meet OSHA requirements or plant specifications where a valve must return to the closed position after operation. Unlike a standard lever handle or gear operator which will remain in the last position, our assemblies ensure that the handle will always spring return to its original, pre-designated starting position.

Spring handles are available for most quarter-turn valve types through 400 inch pounds output torque. These handles are available for retrofitting in the field.

HANDLE SPECIFICATIONS

SPRING CASE:

DIE CAST ZINC ALLOY WITH EPOXY FINISH

COVER SHIELD:

NYLON

SHAFT:

STAINLESS STEEL

LEVER:

STAINLESS STEEL*

(*FOR STANDARD HANDLES;

ON CUSTOMIZED HANDLES, CARBON STEEL IS USED)

*FAIL SAFE HANDLES FOR
BALL VALVES AND BUTTERFLY VALVES*

*AVK CARBO-BOND CAN MOUNT TO
VIRTUALLY ANY VALVE TYPE, MAKE OR MODEL*

*NEW ISO MOUNT ALLOWS FOR DIRECT MOUNTING
TO ISO BALL AND BUTTERFLY VALVES*

*FUSIBLE LINKS ALSO AVAILABLE FOR
FIRE SAFE APPLICATIONS*

FEATURES

- *MANUAL UNIT CANNOT BE LEFT IN THE WRONG POSITION*
- *RELIABLE LOW STRESS CLOCK STYLE SPRINGS*
- *WEATHERPROOF SEALED SPRING HOUSING*
- *CLOCKWISE OR COUNTERCLOCKWISE ROTATION AVAILABLE*
- *TOUGH CORROSION RESISTANT EPOXY PAINT*
- *HEAVY DUTY CUSTOMIZED MOUNTING KIT (STAINLESS OR CARBON STEEL)*
- *AVAILABLE IN FACTORY ADJUSTED TORQUES FROM 36 TO 400 IN LBS*
- *CUSTOMIZED SPRING HANDLES UP TO 830 INCH POUNDS SPRING END AVAILABLE*

SPRING RETURN "DEADMAN" HANDLES

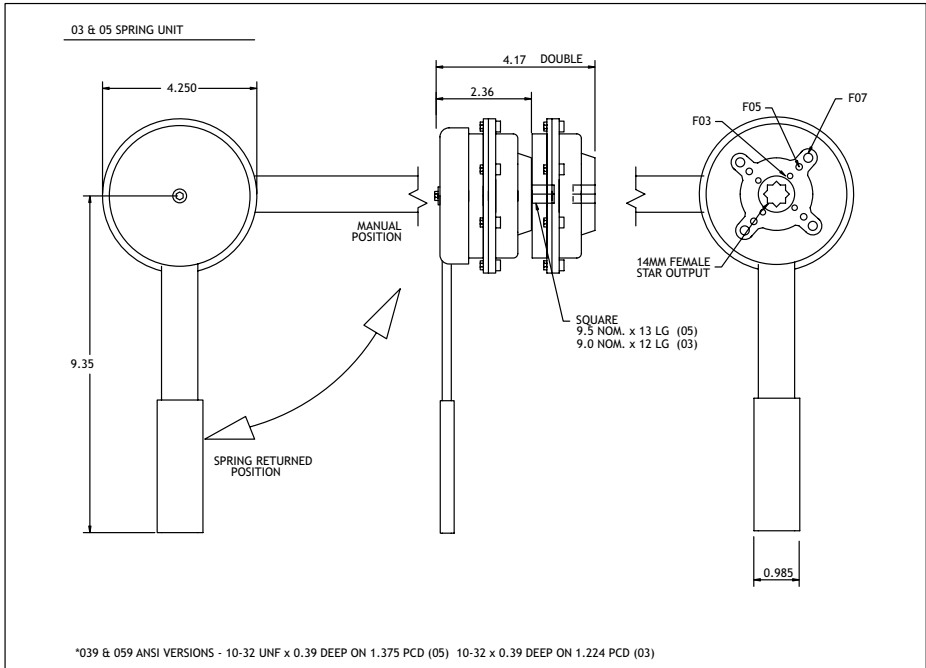

ISO PAD FOR DIRECT MOUNT
The 03 version is available with F03, F04 and F05 mounting flanges and the 05 versions are available with F03, F05 and F07 flanges.

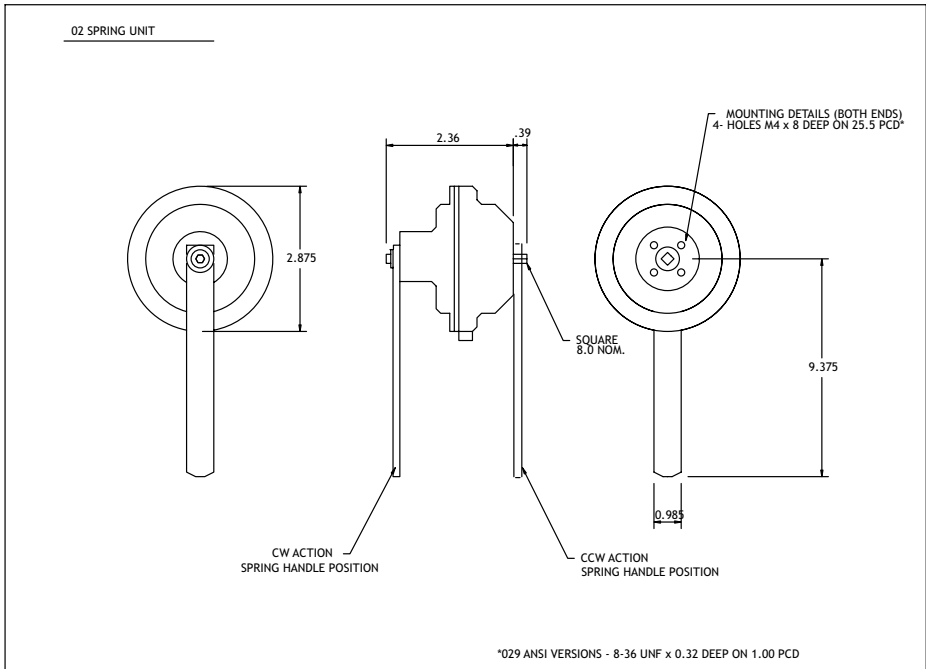

| MODEL NUMBER | SPRING START TORQUE | SPRING END TORQUE | HANDLE SIZE |
|-----------------|---------------------|-------------------|-------------|
| 029-020-1006 | 45 | 36 | 4.33" |
| 039-020-1006 | 123 | 97 | 9.35" |
| 059-020-1006 | 210 | 179 | 9.35" |
| 059-020-1007 | 400 | 349 | 9.35" |
| 079-020-DEADMAN | 450 | 375 | 20" |
| 089-020-DEADMAN | 625 | 530 | 24" |
| 099-020-DEADMAN | 925 | 830 | 30" |