



**AVK CARBO-BOND, INC.**  
AUTOMATED VALVE MOUNTING KITS



BROCHURE  
AVK-2004-01

**CUSTOMIZED VALVE AUTOMATION HARDWARE**



WE DON'T JUST GO WITH THE FLOW . . . WE HELP CONTROL IT

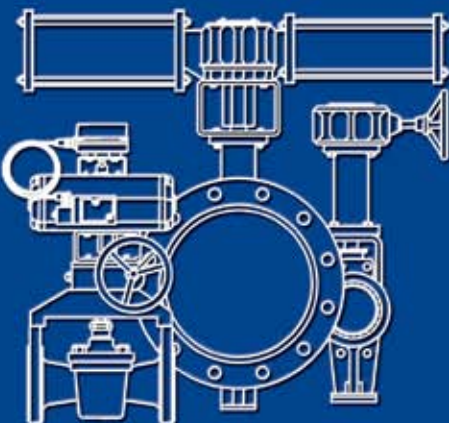

*Valve to Actuator Mounting Kits*

*Limit Switch & Accessory Kits*

*Valve Stem Extensions*

*Lock-Out Devices*

*Deadman Handles*

*Fusible Link Assemblies*

*3-Way Tee Linkages*

*Mounting & Testing Facilities*

*. . . And Much, Much More*

**48 HOUR EMERGENCY SERVICE AND  
EXPEDITED DELIVERY ARE OUR SPECIALTIES**

ENGINEERING VALVE AUTOMATION SOLUTIONS SINCE 1981

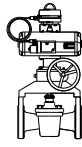

## CUSTOMIZED VALVE TO ACTUATOR MOUNTING KITS

THE ENGINEERS AT AVK CARBO-BOND HAVE DESIGNED MORE CUSTOMIZED MOUNTING KITS THAN ANY OTHER VALVE AUTOMATION HARDWARE MANUFACTURER IN THE WORLD

OVER 26,000 CATALOGED DRAWINGS ON OUR AUTOCAD® SYSTEM FOR ALL MAJOR VALVE AND ACTUATOR MANUFACTURERS

### THOUSANDS OF KIT DESIGNS FOR:

- VALVES TO ACTUATORS
- VALVES TO GEARS AND DECLUTCHABLE MANUAL OVERRIDES
- ACTUATORS TO SWITCHES & POSITIONERS
- AND MUCH, MUCH MORE

For the past two decades, AVK Carbo-Bond has engineered complete bracket, coupler and mounting hardware assemblies to mount any ball, butterfly, plug, gate or damper valve to any make or model of actuator. Our wide range of AutoCad® engineered drawings ensures that we can link virtually any automated valve assembly, whether the valve has been in line for 20 years or needs to be installed by the end of the week. Carbon steel, stainless steel and epoxy-coated options are available for most mounting kits. We also offer a full range of mounting kits for limit switches and positioners to actuators or manual valves.

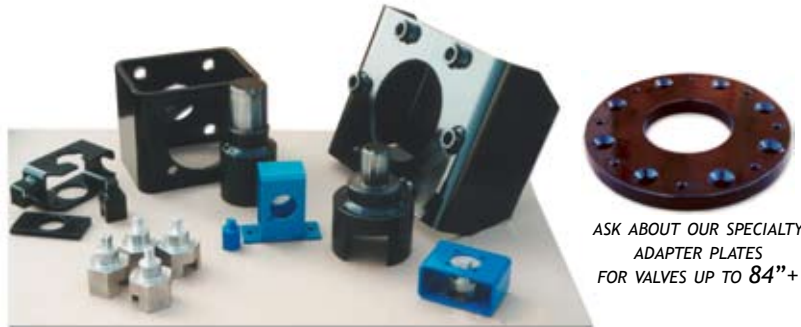

ASK ABOUT OUR SPECIALTY  
ADAPTER PLATES  
FOR VALVES UP TO 84"+

### CUSTOMIZED BROACHING

AVK CARBO-BOND SPECIAL BROACHES  
DRIVE BUSHINGS FOR ROTORK, EIM,  
LIMITORQUE, AUMA, MASTERGEAR  
AND MORE



**WE OFFER 48 HOUR EMERGENCY SERVICE FOR PLANT SHUTDOWNS**

## LOCK-OUT KITS



### FOR MANUAL VALVES

Simplicity is the key to the AVK Carbo-Bond pipe mount lockout kit. By utilizing common features on all ball valves, the pipe mount lockout adapts to all makes of bar stock, cast and three-piece valves to create a tamper-proof manual valve assembly. In addition, we offer a wide range of other manual valve handle options, including chain wheels, overhead lever handles, tee-bars, kits to mount limit switches to manual valves and heat extensions to protect the valve operator.

### FOR AUTOMATED VALVES

AVK Carbo-Bond's newest design offers the perfect solution for locking devices on automated valves requiring safety during maintenance operations or protection for critical system valves. The lockout system is designed as an integral part of the mounting kit and is available for both the "locked open" and "locked close" positions. The lockout pin is attached to the bracket with a keeper chain and can be stowed in a pin storage tube.

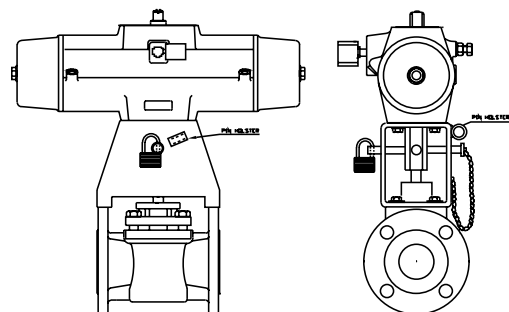

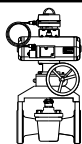

## FAIL SAFE FUSIBLE LINK ASSEMBLIES

WITH AVK CARBO-BOND'S UNIQUE DESIGN . . . ONE VALVE DOES IT ALL

*\*USE ONE VALVE AS BOTH A FIRE SAFE FUSIBLE LINK ASSEMBLY AND AS A MANUALLY OPERATED VALVE\**

- PROVIDES AUTOMATIC CLOSURE IN EVENT OF FIRE
- API 607 FIRE SAFE VALVE AVAILABLE WITH ANSI FLANGES, NPT, OR ALTERNATE ENDS
- SOLDERED FUSIBLE LINKS AVAILABLE IN 135° F THROUGH 360° F
- AVAILABLE WITH VALVE HANDLE OR DECLUTCHABLE MANUAL OVERRIDE

### APPLICATION INFORMATION

Our fusible link assemblies are designed for fail safe situations where high temperature heat from fire results in a main valve springing closed when the fusible link breaks. This specially designed system incorporates an API 607 fire rated valve, a spring loaded operator, a fusible link and our unique AVK Carbo-Bond mounting assembly. The most common application for a fusible link is as a containment system on a gas line to shut off flow through the pipeline during a fire.



**LOW TORQUE SERIES**  
FOR VALVES UP TO 150 IN LBS TORQUE



**MID TORQUE SERIES**  
FOR VALVES UP TO 800 IN LBS TORQUE



**HIGH TORQUE SERIES**  
FOR VALVES UP TO 21,000 IN LBS TORQUE



TOP VIEW OF ASSEMBLY  
WITH SAFETY DUMMY LINK

*ANOTHER QUALITY AVK CARBO-BOND  
CUSTOMIZED VALVE AUTOMATION PRODUCT*

### ASSEMBLY FEATURES

**SPRING PACK:** Features weatherproof sealed spring housing and corrosion resistant epoxy paint. Reliable low stress range springs give consistent clockwise action.

**MOUNTING KIT:** Minimum 1/4" gauge bracket and top plate thickness provide the same durable construction as all AVK Carbo-Bond products.

**VALVES:** Our API 607 ball valve features graphoil packing and metal-to-metal sealing. Available in carbon or 316 stainless steel construction. We can also mount to any other manufacturer's fire-rated ball valve.

**FACTORY ASSEMBLY:** All AVK Carbo-Bond fusible link assemblies are mounted and tested at the factory so the units are ready to put in line when they reach your hands.

**FUSIBLE LINKS:** Soldered type fusible links are available in a variety of temperatures.

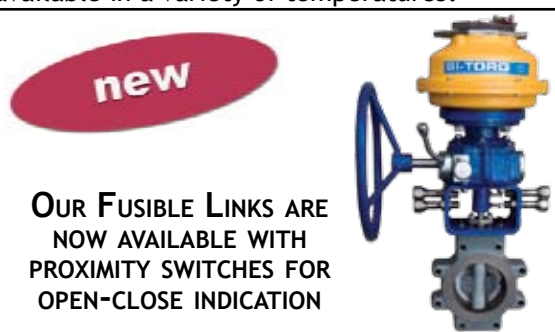

**OUR FUSIBLE LINKS ARE  
NOW AVAILABLE WITH  
PROXIMITY SWITCHES FOR  
OPEN-CLOSE INDICATION**

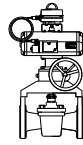

## SPRING RETURN DEADMAN HANDLES

Spring return “deadman” handles will help you meet OSHA requirements or plant specifications where a valve must return to the closed position automatically after operation. Unlike a standard lever handle or gear operator which will remain in the last position, our assemblies ensure that the handle will always spring return to its original, pre-designated starting position.

Spring handles are available for most quarter-turn valve types through 400 inch pounds output torque. These handles are available for retrofitting in the field.



## LIMIT SWITCH AND POSITIONER KITS

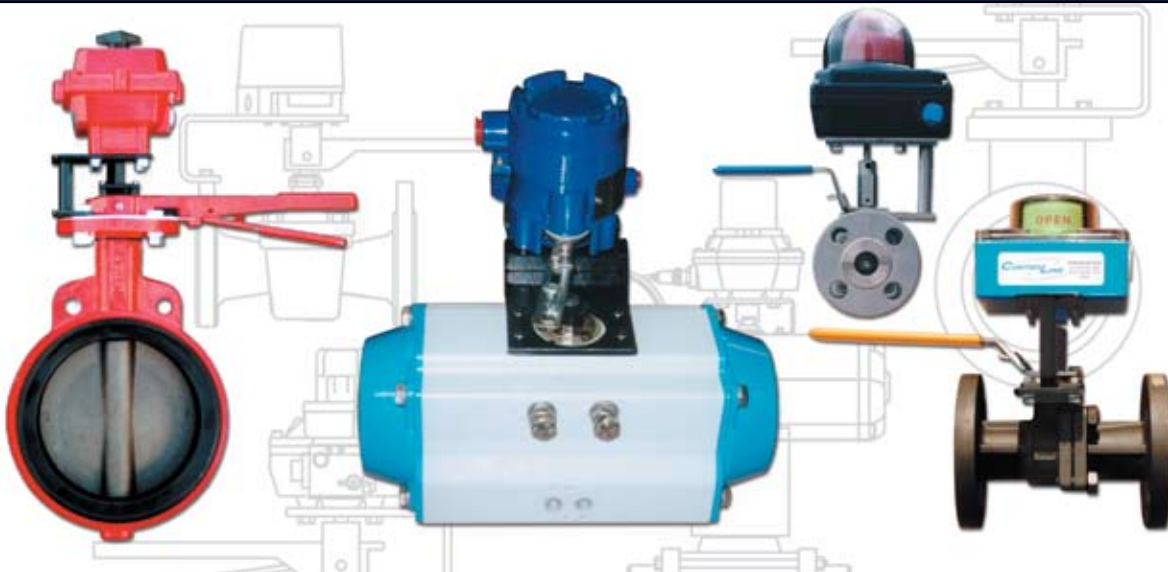

AVK Carbo-Bond manufactures a wide range of customized mounting kits for:

**PNEUMATIC POSITIONERS TO PNEUMATIC ACTUATORS**  
both NAMUR and non-NAMUR styles  
**LIMIT SWITCHES TO PNEUMATIC ACTUATORS**  
both NAMUR and non-NAMUR styles

**LIMIT SWITCHES TO MANUAL VALVES**  
**special application--**for manually operated butterfly and ball valves to any type of switch



In addition, we can create a variety of other mounting hardware for a other automation accessories, including **filter regulators, flow meters, solenoids and more.**

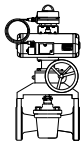

## VALVE EXTENSIONS

### STEM EXTENSIONS:

Our customized stem extensions are designed for use inside tanks, coffer dams, tank sides or catwalks where the valve handwheel, gear operator or actuator must be extended for operator accessibility. A mounting bracket complete with thrust bearing is furnished to carry the weight of the extension and eliminate load on the valve stem. Most extensions over three feet are supplied with universal couplings to ensure smooth operation. One additional mounting bracket is provided at the top of the extension for the operator plus one stabilizing bracket per six feet

### BURIED SERVICE EXTENSIONS:

These extensions are designed specifically for buried or submerged service lines. These extensions are furnished complete so they are ready for field installation to pneumatic, electric, hydraulic or gear operators. AVK Carbo-Bond extensions are fitted with thrust support bearings to carry the full weight load of the extension shaft, eliminating load on the valve stem. Top alignment bearings eliminate side load on the valve or actuator and simplify installation. The extension shaft is enclosed completely in a steel outer torque tube housing.

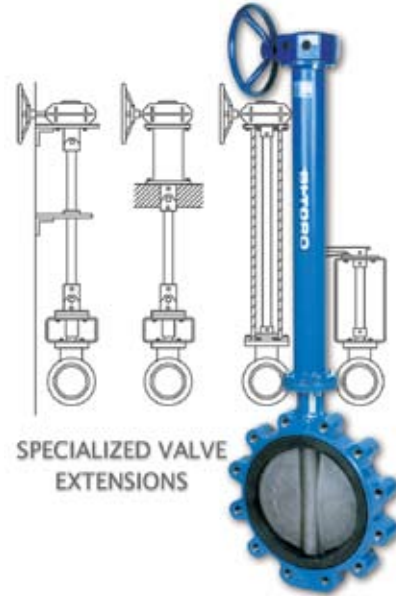

## THREE-WAY TEE LINKAGES



### FEATURES

- ECONOMIC ALTERNATIVE TO LARGE 3-WAY VALVES
- IDEAL FOR MIXING APPLICATIONS
- VARIETY OF MASTER-SLAVE ARRANGEMENTS
- ADJUSTABLE LINKAGES
- HIGH QUALITY ROD END BEARINGS
- COMPLETE PACKAGES AVAILABLE, INCLUDING VALVES, ACTUATORS, TEES AND FLANGE PACKS
- FULL SERVICE FACTORY ASSEMBLY AND TESTING

### ARRANGEMENT OPTIONS

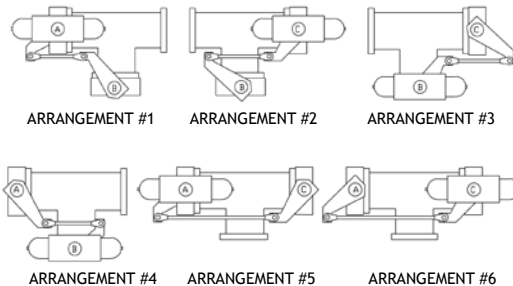

The use of butterfly valve tee linkages provides an economic alternative to larger sized three-way ball valves. By incorporating a flanged tee, our specialized linkage arms and mounting kits, our engineers can design a master-slave arrangement so that only one actuator operates two valves. AVK Carbo-Bond tee linkages are adjustable and use high quality rod end spherical bearings to ensure smooth, reliable operation. We also offer a complete mounting and testing service with your choice of valves and actuators, or we can provide an entire package including our own butterfly valves and actuators.

ALSO ASK ABOUT OUR  
BALL VALVE LINKAGES AND  
SPECIALTY HVAC LINKAGES





**CARBO-BOND, INC.**  
AUTOMATED VALVE MOUNTING KITS

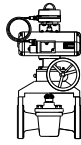

ENGINEERING VALVE AUTOMATION  
HARDWARE SINCE 1981

## MOUNTING AND TESTING FACILITIES

Thanks to our **full service** facilities, our team can mount and test complete valve automation assemblies. This means we can direct ship a "ready to put in line" assembly to your customer, saving valuable time and ensuring that the product will work when it gets to the site. Whether you require a basic actuator to valve assembly or a complete package with positioners, switches, solenoids and/or gear operators, let us assemble and test the units for you.

### *MOUNTING AND TESTING AVAILABLE FOR:*

**PNEUMATIC ACTUATORS AND CYLINDERS**

**ELECTRIC ACTUATORS**  
115VAC, 220VAC, 12VDC, 24VDC, 24VAC

**SOLENOID VALVES**  
115VAC, 220VAC, 12VDC, 24VDC, 24VAC

**PNEUMATIC POSITIONERS**  
3-15 PSI OR 4-20 mA INPUT

**LIMIT SWITCHES**  
PROXIMITY AND MECHANICAL SWITCHES

**DECLUTCHABLE GEAR OPERATORS**

**FILTER REGULATORS**

**AND MUCH MORE . . .**



## ABOUT AVK CARBO-BOND, INC.

AVK Carbo-Bond, a family-owned company based in La Fox, Illinois, has provided full service engineering and manufacturing of customized valve automation kits since 1981. Since the beginning we have received praise within the industry for our service and ingenuity. In addition to our customized brackets and couplers, we also manufacture positioner and limit switch brackets, three-way tee-linkage packages, stem extensions, protection for buried service situations, chain handles, locking kits, fusible link assemblies and a variety of other valve automation accessories. Our engineering staff has experience with virtually every automated valve component available in the industry today and has a broad catalog of AUTOCAD drawings at their disposal.

We have come a long way since our early days as an abrasive company specializing in white wall tires. Although we retained the name "Carbo-Bond," we added the "AVK" in 1981 to represent our shift to the "Automated Valve Kit" business. We became a pioneer in manufacturing mounting kits that would link different manufacturers' valves to a variety of actuators, gears and switches. In many ways, AVK Carbo-Bond helped to change the face of the valve industry thanks to our ingenuity and willingness to do anything it takes to satisfy our customer base.

## OUR MISSION: TOTAL CUSTOMER SATISFACTION

**AVK CARBO-BOND, INC.**  
1N046 LINLAR DRIVE  
LA FOX, IL 60147 USA  
TEL: 630-208-9343  
FAX: 630-232-6235

ON THE WEB AT  
[WWW.BITORQ.COM](http://WWW.BITORQ.COM)

