

PAO SERIES SPRING RETURN ELECTRIC ACTUATOR

Actuator Specifications	PAO Series 450"lbs / 50Nm		
Torque lb/Nm	450"lbs / 50Nm		
Supply Voltage	24VAC/DC	120VAC	230VAC
Max Inrush Current	4.0A	2.8A	1.3A
Running Current	3.0A	1.5A	0.7A
Runtime (90°@60/50Hz)	7.0 sec	7.0 sec / 9.0 sec	
Runtime (90° Spring)	3.0 sec	3.0 sec	
Weight	82lbs / 37kg		
Mechanical Connections	ISO5211 F07 8pt 17mm		
Electrical Entry	(2) 3/4" NPT		
Electrical Terminations	12 - 16 Ga.		
Environmental Rating	4, 4X		
Manual Override	7.6" HandWheel		
Control	On/Off/Jog/Proportional		
Case material	Aluminum Alloy, Powder Coated		
Motor Protection 120vac or 230vac Operation	Split Phase Capacitor 275°F/135°C Thermal F Class		
Motor Protection 24vac or 24vdc Operation	Brush type DC Motor 275°F/135°C Thermal F Class		
Ambient Temperature	-22°F to +150°F		
Operating Range	-30°C to +65°C		

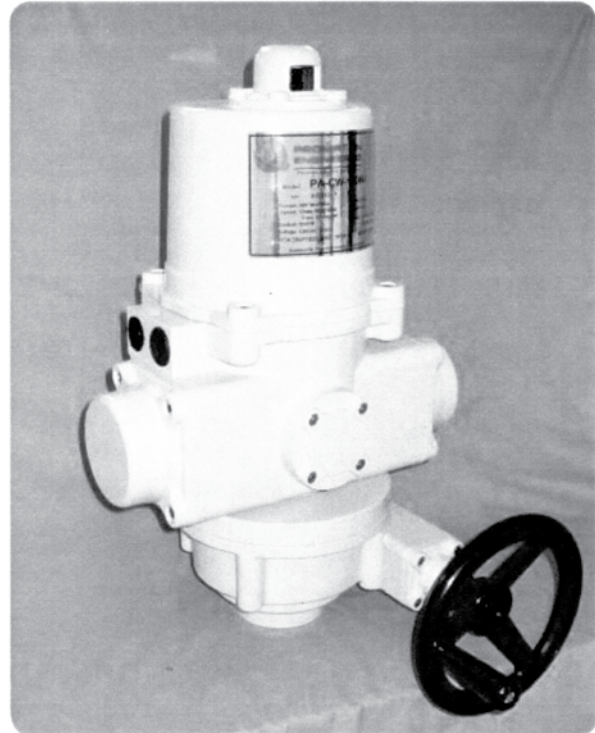

A SPRING RETURN electric actuator designed for load requirements up to 450"lbs. The actuator comes standard with two auxiliary switches (Form C), an internal low power heater, a NEMA 4X environmental rating, and in 120/230VAC or 24VAC/DC supply voltages. The PAO Series mechanical connections utilize an ISO5211 mounting system, size F07 with an 8 point 17mm female drive. The PAO Series is offered in three different control modes....On/Off (2 position control), Jog (floating control) and Proportional (modulating control). Application requirements will dictate whether to utilize a CW (clockwise spring return) or CCW (counter-clockwise spring return) model.

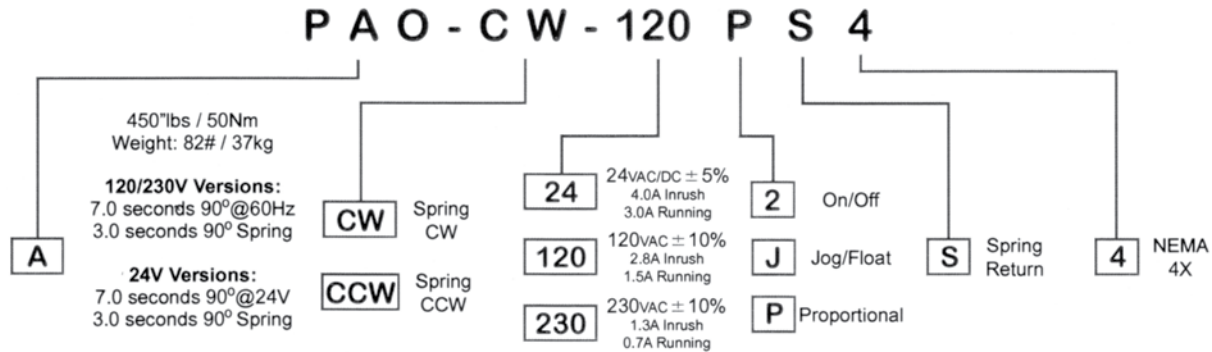

Theory of Operation

While power is present, the actuator will respond to drive control signals depending on the model chosen. A 2 position unit will drive until it reaches the full end of travel setting opposite the spring return direction. A Jog unit will drive OPEN, CLOSED or HOLD position until it receives a command to move otherwise. A Proportional control unit will follow an analog control signal for positioning and will HOLD until a modified control signal is received. In each of these models a motor brake unit is utilized to HOLD the actuator in position until commanded to move OR a loss of supply voltage. If power is lost or removed at any time, the brake is released and the mechanical spring mechanism returns the actuator to it's normal (unloaded) position. Once the spring mechanism has been released, the actuator will not drive under power again until a) the unit has reached it's fail stop (unloaded) position, and b) power has been restored to the actuator. While the actuator is in it's fail stop position, the MANUAL HANDLE may be employed to position the actuator anywhere between the UNLOADED and LOADED position, and the actuator will HOLD in that position indefinitely, regardless of whether power is present. The MANUAL HANDLE must return the actuator to its fully UNLOADED position BEFORE electrical operation of the actuator will be possible. **THIS IS A SAFETY FEATURE.** Additionally, if the actuator has been driven electrically to its fully LOADED position, the MANUAL HANDLE cannot be used to drive the actuator back to its fully UNLOADED position. **THIS IS ALSO A SAFETY FEATURE.** This prevents unexpected release of stored spring energy. Remote indication of actuator status is possible by utilizing built-in auxiliary switches. These dry contacts can show when an actuator has been overridden after power has been restored, indicating the actuator will NOT operate under control again until it has been manually returned to the full Fail-Safe position (explained above).

PAO SERIES SPRING RETURN ELECTRIC ACTUATOR

Application Notes:

1. These actuators are designed to be used in either a horizontal or upright position.
Do NOT mount the actuator with the top below a horizontal position.
2. When installing conduit, use proper techniques for entry into the actuator. Use drip loops to prevent conduit condensate from entering the actuator.
3. Both NPT conduit ports MUST use proper equipment to protect the NEMA 4x integrity of the housing.
4. The internal heater is to be used in ALL applications.
5. Do NOT install the actuator outdoors or in humid environments unless it is powered up and the heater is functioning.
6. Use proper wire size to prevent actuator failure (see chart below for proper wire sizing).
7. Mechanical travel stops are factory calibrated for 90 degree operation. These stops are NOT designed to adjust mechanical rotation by more than +/- 3 degrees.

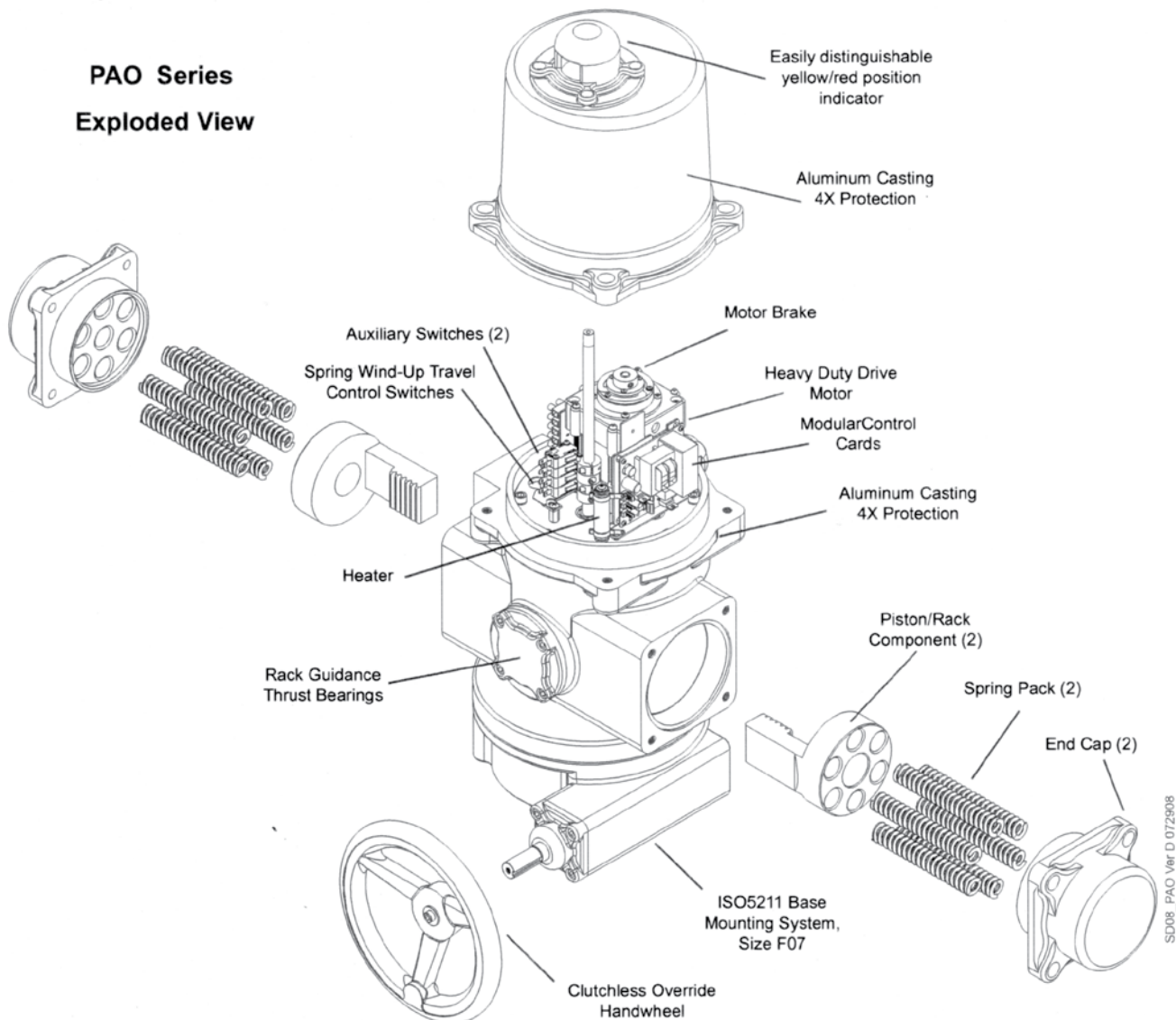

A modular cast aluminum housing incorporates the mechanical drive train, the spring pack and rack assemblies, the output drive shaft, motor and control section and the manual override handwheel unit. The spring pack is NOT field servicable and spring failure direction mode must be selected at time of order.

CAUTION!.....spring packs are under **EXTREME** tension and must **NOT** be altered or modified under any circumstances. Do **NOT** remove any bolts or screws from the actuator housing other than the **(4) TOP COVER SCREWS**. Failure to comply with this warning could cause **severe bodily injury**.

PAO SERIES SPRING RETURN ELECTRIC ACTUATOR

Wiring Diagrams for PAO Series

Field Control Device may be relay contact, Switch or Triac type. Pilot device 10A MAX. Auxiliary switches are rated 10A @ 250vac MAX. Terminals 7-12 (Jog/Proportional) and A-F (On/Off) are dry type Form C. Terminals accept 12-18ga solid/stranded wire.

On/Off/2 Position Control

On/Off or 2 Position control is used for damper or valve applications where the requirement is for either fully open or fully closed positioning. This actuator must drive to it's end of travel opposite the spring fail position. Loss of control signal or power before reaching it's end of travel will cause the unit to spring return.

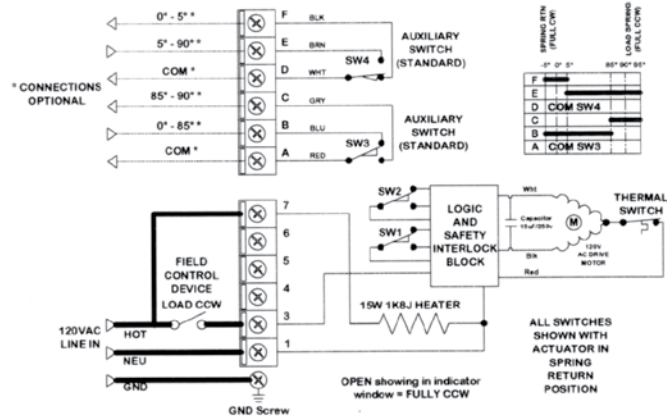

Jog/Floating Control

Jog/Floating control is used for damper or valve applications where the requirement is for the device to be controlled with a standard floating controller that can drive one direction, stop in mid stroke, then drive in the opposite direction or any combination thereof. In this scheme, the motor brake will engage any time the drive motor is NOT moving under power. Only a loss of supply POWER will cause the spring mechanism to fail-position the actuator.

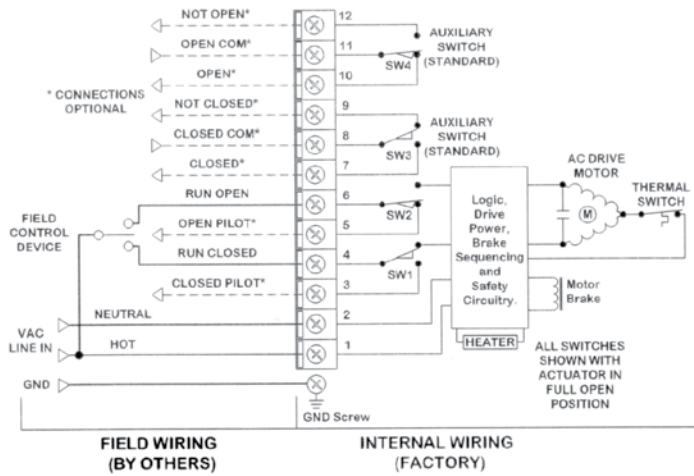

Proportional Control

Proportional control is used for damper or valve applications where the requirement is for the device to follow an analog control signal to provide modulating control of the device. The unit will accept various control signal inputs (4-20mA, 2-10vdc, 0-10vdc, 1-5vdc, custom) and also will provide an analog feedback signal for external signal referencing. In this scheme, the motor brake will engage any time the drive motor is NOT moving under power. Only a loss of supply POWER will cause the spring mechanism to fail-position the actuator. However, a loss of control SIGNAL can be programmed to drive the actuator to either a fully open, fully closed or to fail-in-position.

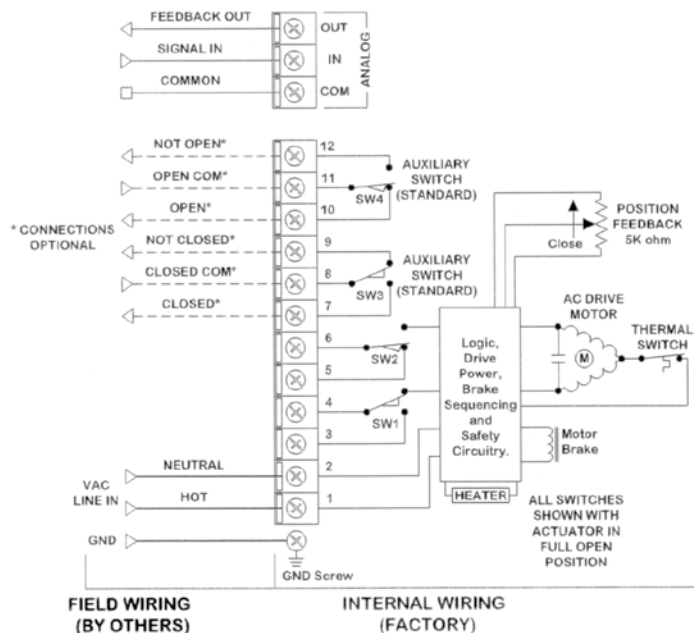

PAO SERIES SPRING RETURN ELECTRIC ACTUATOR

Wire Sizing Data

MAX distance between Actuator and Supply (feet)			
Wire Gage	PAX-24XS4 4.0A	PAX-120XS4 2.8A	PAX-230XS4 1.3A
18	41	295	1218
16	65	464	1915
14	105	749	3093
12	160	1146	4731
10	273	1948	8042
8	407	2908	12003

Wire sizing data is provided in the table above to assist in the selection of the proper wire size for ProMation PAO series actuators using various wire sizes over distance. Please make sure to reference the correct voltage and do not exceed the indicated length of the wire run for each model.

**Dimensional Data
PAO Series**

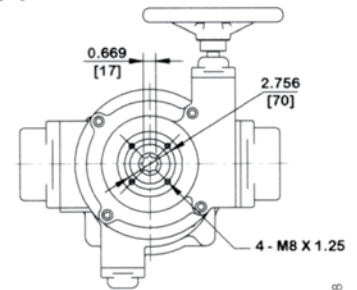
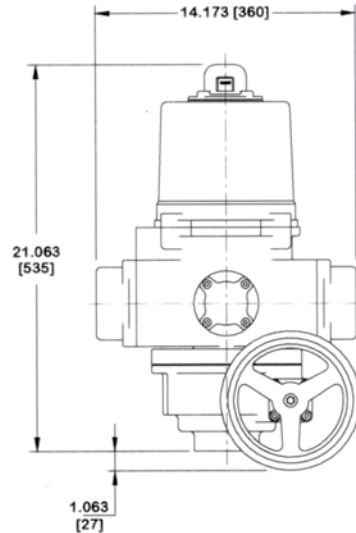
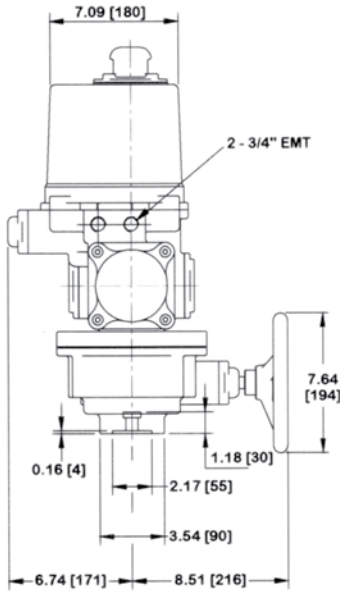
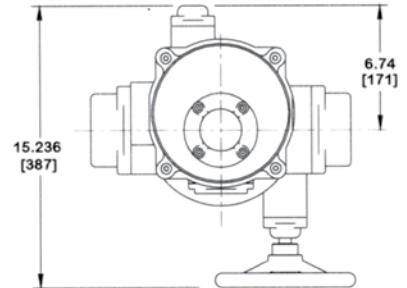

**Switch Logic Map and
Switch/Cam Arrangement**

Switch sequencing data is provided in the tables below to show the change-of-state points during the rotation of the actuator from CW to CCW and back again. The LOWER 2 cams are set at the factory and MUST NOT be changed. The INCLUDED auxiliary switches SW3 & SW4 are for terminals 7 thru 12 (Jog & Proportional control), and terminals A thru F (On/Off control) and those setpoints may be modified if need be.

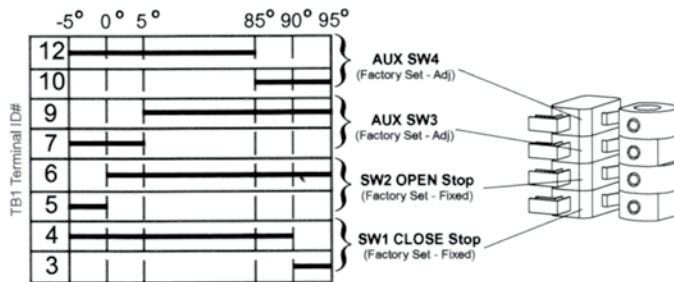

Switch/Cam arrangement for Jog & Proportional control

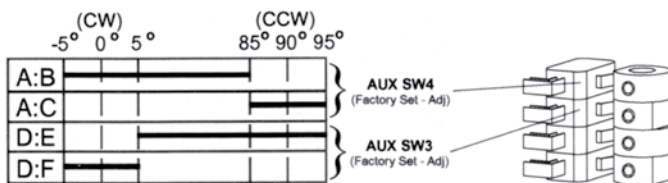

Switch/Cam arrangement for On/Off control

Preliminary Product Data Sheets

This document may change slightly when production models are ready for shipment. Slight changes to the wiring diagrams may be possible. However, mechanical and dimensional data are

SD08_PAO_Ver D 072908