

INSTALLATION & MAINTENANCE FOR MT-SERIES ASSEMBLIES

I. OVERVIEW OF FUSIBLE LINK ASSEMBLIES

AVK Carbo-Bond fusible link valve assemblies are designed for flow shutoff protection in piping systems handling flammable gasses or liquids, solvents, toxic fluids, or any other potentially dangerous media. These fire control valves terminate flow in the event of fire, aiding in reducing fire intensity. In the event of fire, the fusible link separates, allowing the top mounted spring pack to drive an API607 fire safe rated valve into a closed position. Fusible links are available in a range of temperature settings. The fusible link valve assembly also is available in a fail open position, ideal for a sprinkler system in the event of a fire.

The fusible link assembly you have received has been assembled and tested at our factory with attention to safety in mind. AVK Carbo-Bond uses high quality materials and tested engineering to ensure that this product will operate safely and reliably. Carefully read all instructions before handling in order to avoid injury to the operator or damage to the product.

NOTE: Please refer to the attached assembly drawing FL-MW-0600 for parts identification and complete parts list.

II. GENERAL SAFETY INSTRUCTIONS

WARNING: This fusible link assembly has been shipped from the factory in the armed position and is ready for installation in line. Use extreme caution in handling the assembly because the spring pack is under full tension at all times.

For shipping purposes, the fusible link has been replaced with a safety link (#9). This part can be identified as the part that is PAINTED RED. (see illustration 2.1)

IMPORTANT: THE SAFETY LINK MUST BE REMOVED AND REPLACED WITH THE FUSIBLE LINK AFTER THE VALVE HAS BEEN PUT IN LINE. IF SAFETY LINKS ARE NOT REMOVED, FUSIBLE LINK WILL NOT OPERATE CORRECTLY.

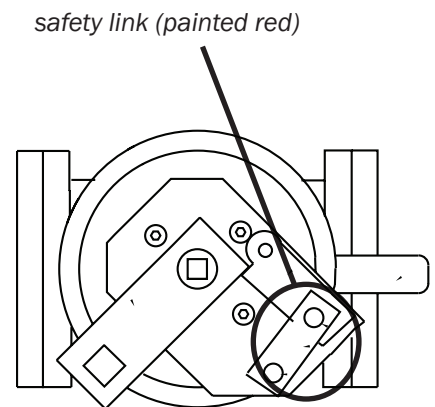

illustration 2.1

The unit must be installed in a location with carefully maintained ambient temperatures. Installing the link in locations where high temperature fluctuations are possible (such as direct sunlight) is not recommended. Exposure to high ambient temperatures can cause the fusible links to break prematurely. (See chart 1 for link temperature ratings for spring packs 079/089; chart 2 for 099.)

Part Number	Yield Temp.	Max. Ambient Temp.
FL-1-165	165° F / 74° C	135° F / 57° C
FL-1-212	212° F / 100° C	185° F / 82° C
FL-1-280	280° F / 138° C	253° F / 123° C
FL-1-360	360° F / 182° C	330° F / 166° C

chart 1

INSTALLATION & MAINTENANCE FOR MT-SERIES ASSEMBLIES

III. INSTALLING FUSIBLE LINKS ON THE MID-TORQUE SERIES ASSEMBLY

Please refer to the attached assembly drawing FL-MW-0600 for parts identification and complete parts list.

NOTE: THE UNIT HAS BEEN SHIPPED IN THE ARMED (OPEN) POSITION WITH A SAFETY LINK.

IMPORTANT: ALWAYS INSTALL LINKS WITH VALVE IN LINE OR SECURED IN VISE

REQUIRED TOOLS: 1/2" open ended wrench to install 5/16" x 18 nuts

1. Remove 5/16" x 18 nuts on link retaining studs (#10) securing red safety link.
2. Insert the detachable handle onto the square hole on the arming lever (#7).
3. Apply pressure on the detachable handle toward the open position (CCW) to relieve tension on the safety link (#8).
3. Loosen and remove both 5/16" x 18 nuts on link retaining studs (#10).
4. While maintaining pressure on the detachable handle, remove the safety link and replace with the fusible link.(see illustration 3.1)
5. Place link on retaining arm studs (#10) with 5/16" x 18 nuts until link is held firmly in position. CAUTION: Do not tighten nuts. Tightening will stress the links and could result in improper functioning.
6. Remove detachable handle from arming lever. The unit is now properly armed. NOTE: Ensure that the handle is stored in a location near the valve with the chain provided. The handle will be necessary to re-set the unit when links are changed as part of annual maintenance.

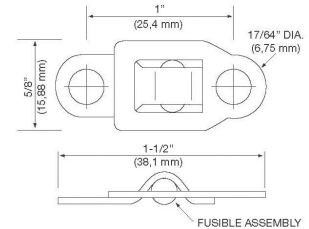

typical fusible link

illustration 3.1

IMPORTANT: FAILURE TO REMOVE DETACHABLE HANDLE FROM ARMING LEVER COULD RESULT IN SERIOUS INJURY OR DEATH. AFTER INSTALLING LINKS STORE HANDLE NEAR THE ASSEMBLY OR IN A WELL-IDENTIFIED LOCATION. UNIT CANNOT BE PROPERLY REARMED WITHOUT HANDLE.

IV. OPERATION

Once the unit is properly armed, the valve may be operated closed-open in the normal manner using the valve handle (#5) without disturbing the fusible link.

V. MAINTENANCE

IMPORTANT: The fusible link manufacturer recommends annual replacement of link(s) as part of a regular maintenance schedule. Contact your local distributor or AVK Carbo-Bond for replacement links. Order by part number or temperature rating on old link. Replacement valve seats and seals subject to normal wear are available from your local distributor or AVK Carbo-Bond.

The spring case and declutchable gear are lifetime lubricated and do not require maintenance. Disassembly of the spring case or gear will void any written or verbal warranties.

WARNING: THE SPRING CASE CLOCKSING IS ALWAYS UNDER PRESSURE. DO NOT DISASSEMBLE SPRING PACK UNDER ANY CIRCUMSTANCES. DISASSEMBLY OF THE SPRING PACK COULD RESULT IN SERIOUS INJURY OR DEATH.

INSTALLATION & MAINTENANCE FOR MT-SERIES ASSEMBLIES

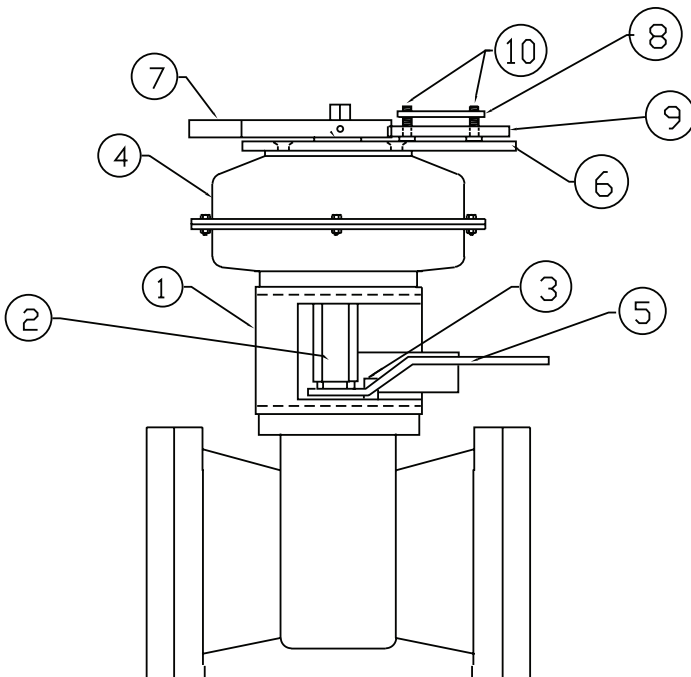
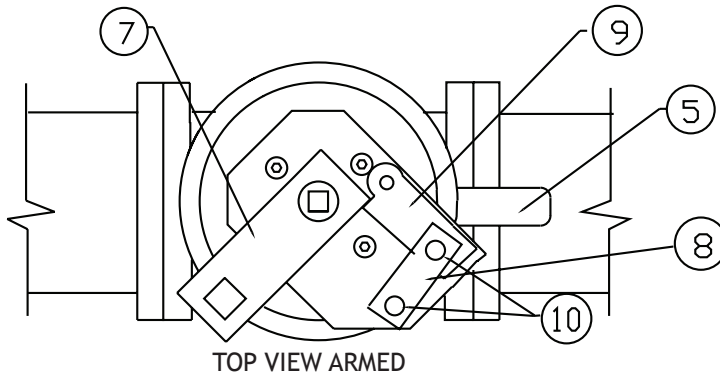
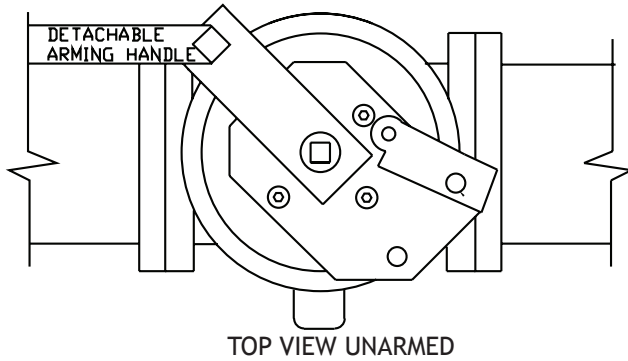

1	SPRING PACK MOUNTING BRACKET	7	ARMING LEVER
2	SPRING CLOSE ASSEMBLY	8	SAFETY LINK
3	VALVE OPEN/CLOSE STOP	9	LEVER RETAINING ARM
4	079/089/099 SPRING PACK	10	FUSIBLE LINK RETAINING STUDS
5	VALVE HANDLE	11	SECURITY STOP
6	FUSIBLE LINK MOUNTING PLATE	12	SPACE WASHER

IMPORTANT: IMPROPER INSTALLATION OR ARMING OF FUSIBLE LINK ASSEMBLIES WILL VOID WARRANTY, AS WILL DISASSEMBLY OF THE PRODUCT WITHOUT PRIOR APPROVAL FROM FACTORY.