

FLP-LT SERIES 1/2" THROUGH 1" 150# FLANGED



Safety link shown for illustration purposes only.

PART NUMBERS	
FLP-MT-059-***-XXX-BV-ED50	includes 316SS flanged API 607 fire safe valve
FLP-MT-059-***-XXX-BV-W50	includes WCB/SS API 607 fire safe valve

***: Select a link temperature from the chart below.
XXX: valve size (i.e., 005=1/2", 007=3/4", 010=1")

LINK PART NUMBER	LINK YIELD TEMPERATURE	MAXIMUM AMBIENT TEMPERATURE
FL-1-165	165°F/74°C	135°F/57°C
FL-1-212	212°F/100°C	185°F/82°C
FL-1-286	286°F/138°C	253°F/123°C
FL-1-360	360°F/182°C	330°F/166°C

NOTE: Links must be replaced on an annual basis as part of a regular maintenance program. Links are not rated for use in corrosive atmospheres.

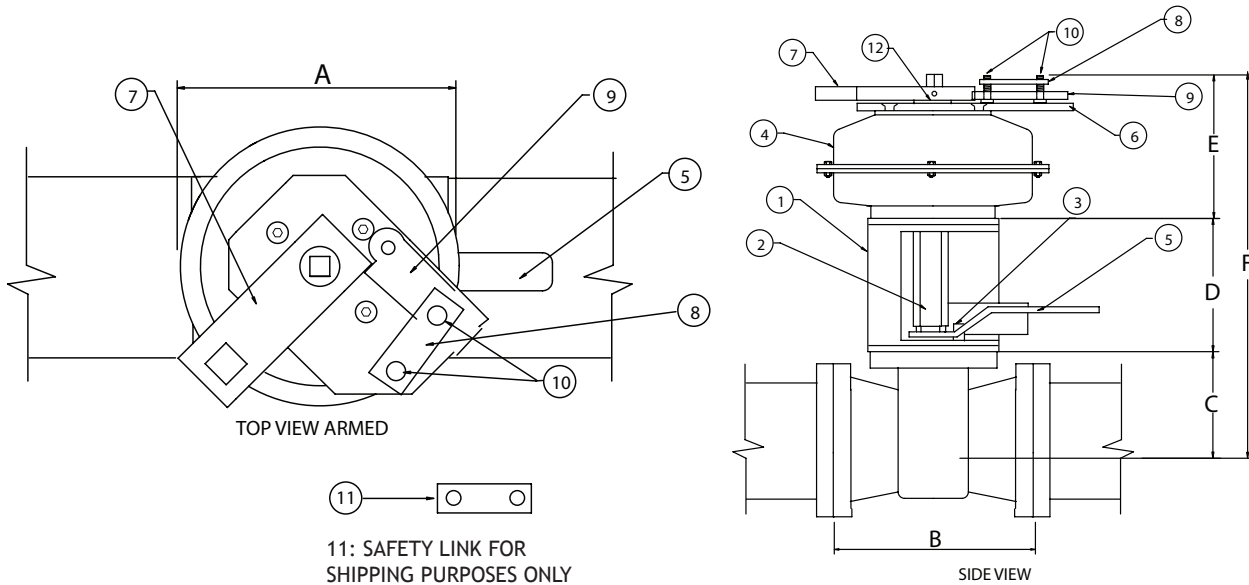

DIMENSIONS

SIZE	1/2"	3/4"	1"
A	4.250	4.250	4.250
B	4.250	4.620	5.000
C	1.510	1.630	1.960
D	3.000	3.000	3.000
E	2.500	2.500	2.500
F	7.010	7.130	7.460
WEIGHT (LBS.)	11.00	13.00	15.00

BILL OF MATERIALS

1	SPRING PACK MOUNTING BRACKET	CARBON STEEL	7	ARMING LEVER	STAINLESS STEEL
2	COUPLER/TRIPPER ARM	CARBON STEEL	8	FUSIBLE LINK	SOLDERED METAL
3	VALVE OPEN/CLOSE STOP	STAINLESS STEEL	9	FUSIBLE LINK RETAINING ARM	STAINLESS STEEL
4	057-030 SPRING PACK	EPOXY COATED STEEL	10	LINK RETAINING STUDS	STAINLESS STEEL
5	VALVE HANDLE	PLATED STEEL	11	SAFETY LINK	CARBON STEEL
6	FL MOUNTING PLATE	STAINLESS STEEL	12	SPACER	NYLON

The policy of AVK Carbo-Bond is one of continuous improvement. We reserve the right to alter the product as described and illustrated without notice.