

# FLP-LT SERIES 1/2" THROUGH 1" NPT



Link shown for illustration purposes only.



PART NUMBERS	
FLP-LT-059-***-XXX-BV-FS	includes 316SS 3-piece API 607 fire safe valve
FLP-LT-059-***-XXX-BV-FW	includes WCB/SS 3-piece API 607 fire safe valve

\*\*\*: Select a link temperature from the chart below.  
XXX: valve size (i.e., 005=1/2", 007=3/4", 010=1")

LINK PART NUMBER	LINK YIELD TEMPERATURE	MAXIMUM AMBIENT TEMPERATURE
FL-1-165	165° F/74° C	135° F/57° C
FL-1-212	212° F/100° C	185° F/82° C
FL-1-286	286° F/138° C	253° F/123° C
FL-1-360	360° F/182° C	330° F/166° C

**NOTE: Links must be replaced on an annual basis as part of a regular maintenance program. Links are not rated for use in corrosive atmospheres.**

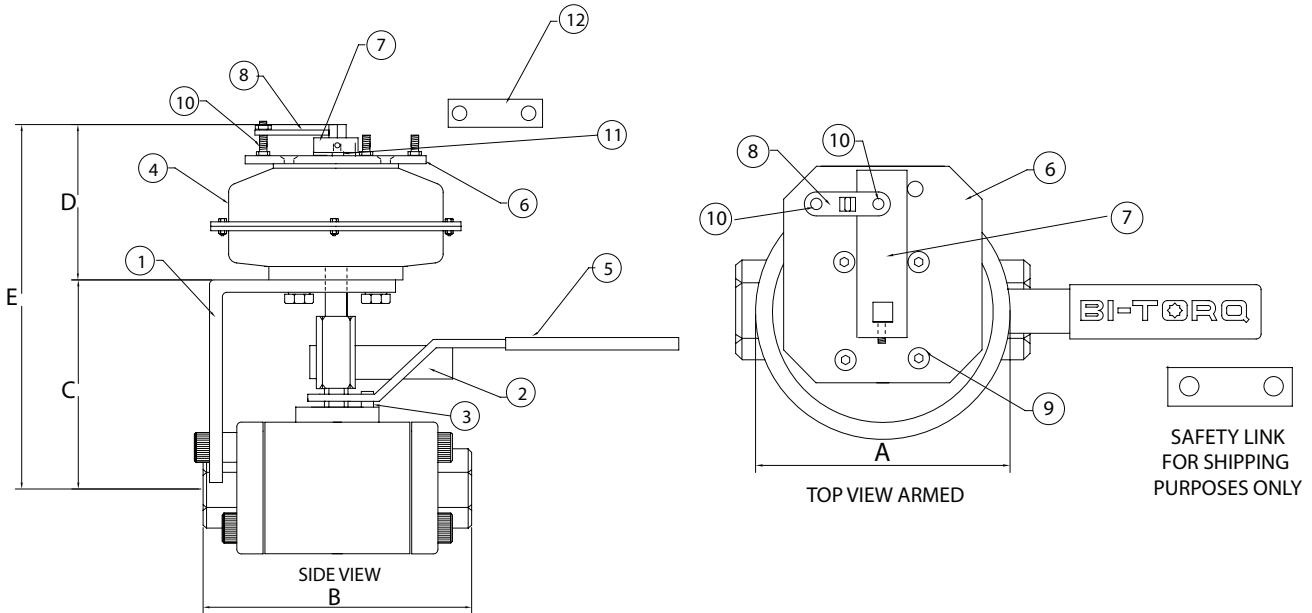

## DIMENSIONS

SIZE	1/2"	3/4"	1"
A	4.250	4.250	4.250
B	3.185	2.965	3.570
C	3.750	4.000	4.625
D	2.500	2.500	2.500
E	6.250	6.500	7.125
WEIGHT (LBS.)	9.62	10.75	12.05

## BILL OF MATERIALS

1	SPRING PACK MOUNTING BRACKET	CARBON STEEL	7	TRIPPER ARM	CARBON STEEL
2	SPRING PACK ARMING ASSEMBLY	CARBON STEEL	8	FUSIBLE LINK	SOLDERED METAL
3	VALVE OPEN/CLOSE STOP	STAINLESS STEEL	9	LEVER RETAINING ARM	STAINLESS STEEL
4	057-030 SPRING PACK	EPOXY COATED STEEL	10	FUSIBLE LINK STUDS	STAINLESS STEEL
5	VALVE HANDLE	STAINLESS STEEL	11	SPACER	STAINLESS STEEL
6	FL MOUNTING PLATE	STAINLESS STEEL	12	SAFETY LINK	CARBON STEEL

The policy of AVK Carbo-Bond is one of continuous improvement. We reserve the right to alter the product as described and illustrated without notice.