

FLP-MT SERIES 2" NPT



FM
APPROVED
TOPWORKS WITH
API 607 FIRE SAFE
BALL VALVE

Link shown for illustration purposes only.

PART NUMBERS	
FLP-MT-089-***-020-BV-FS	includes 316SS 3-piece API 607 fire safe valve
FLP-MT-089-***-020-BV-FW	includes WCB/SS 3-piece API 607 fire safe valve

***: Select a link temperature from the chart below.

LINK PART NUMBER	LINK YIELD TEMPERATURE	MAXIMUM AMBIENT TEMPERATURE
FL-1-165	165° F/74° C	135° F/57° C
FL-1-212	212° F/100° C	185° F/82° C
FL-1-286	286° F/138° C	253° F/123° C
FL-1-360	360° F/182° C	330° F/166° C

NOTE: Links must be replaced on an annual basis as part of a regular maintenance program. Links are not rated for use in corrosive atmospheres.

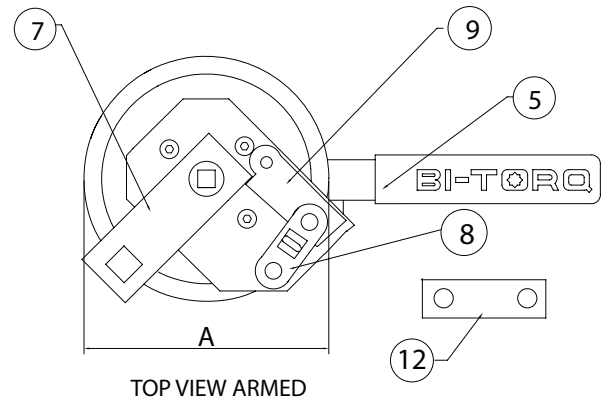
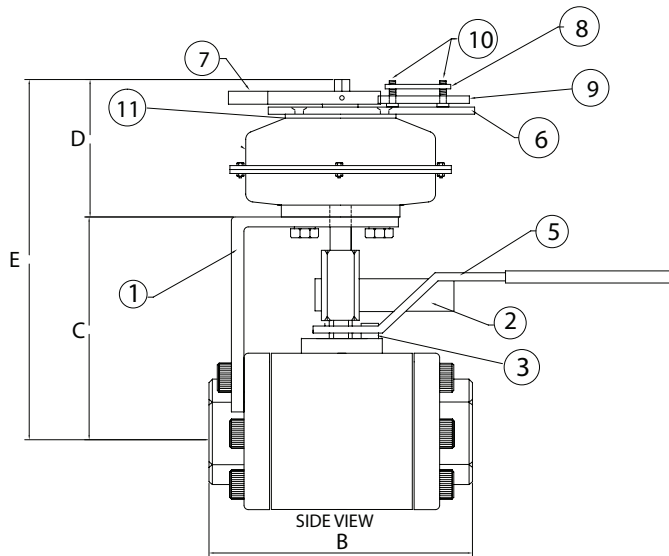

12: SAFETY LINK FOR SHIPPING PURPOSES ONLY

DIMENSIONS

SIZE	2"
A	6.000
B	5.550
C	6.562
D	5.125
E	11.688
WEIGHT (LBS.)	43.05

BILL OF MATERIALS

1	SPRING PACK MOUNTING BRACKET	CARBON STEEL	7	TRIPPER ARM	CARBON STEEL
2	SPRING PACK ARMING ASSEMBLY	CARBON STEEL	8	FUSIBLE LINK	SOLDERED METAL
3	VALVE OPEN/CLOSE STOP	STAINLESS STEEL	9	LEVER RETAINING ARM	STAINLESS STEEL
4	087-030 SPRING PACK	EPOXY COATED STEEL	10	FUSIBLE LINK STUDS	STAINLESS STEEL
5	VALVE HANDLE	STAINLESS STEEL	11	SPACER	STAINLESS STEEL
6	FL MOUNTING PLATE	STAINLESS STEEL	12	SAFETY LINK	CARBON STEEL

The policy of AVK Carbo-Bond is one of continuous improvement. We reserve the right to alter the product as described and illustrated without notice.