



AUTOMATED 3-WAY FLANGED SS BALL VALVE



- Maximum Flow Full Bore Ball Valves 1/2" thru 4" Stainless Steel
- L-Port or T-Port Configurations
- ANSI 150# Flanged Ends
- Electric and Pneumatic Actuators
- 4-Seat Design for high cycling
- Secure True ISO Mounting Pad
- Most models are direct mount for lowest possible stack-up height



PNEUMATIC ACTUATORS

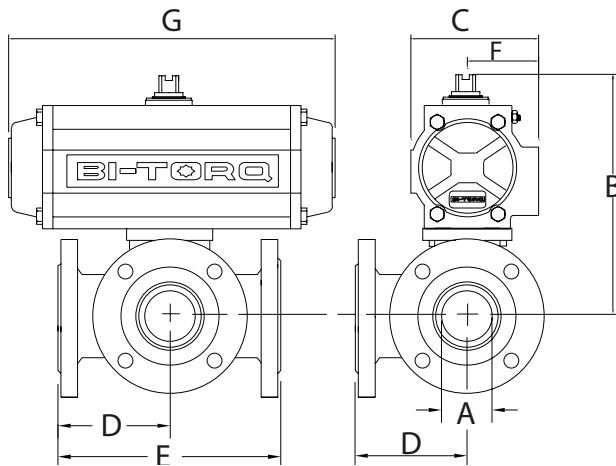

ALL STANDARD PNEUMATIC ACTUATORS SIZED FOR 80 PSI SUPPLY; PLEASE CONSULT FACTORY FOR OTHER COMBINATIONS

A	1/2"	3/4"	1"	1-1/4"	1-1/2"	2"	2-1/2"	3"	4"
B	5.50	5.87	6.03	7.09	8.07	8.74	11.01	11.73	12.52
C	2.80	2.80	2.80	3.17	3.72	3.72	5.83	7.36	7.36
D	2.99	3.29	3.64	3.99	4.33	4.98	5.91	6.01	7.26
E	5.98	6.57	7.28	7.97	8.66	9.96	11.81	12.01	14.54
F	1.61	1.61	1.61	1.77	2.07	2.07	2.87	2.87	2.87
G	5.49	5.49	5.49	6.38	8.15	8.15	12.91	12.91	12.91
ACT.	52DA	52DA	52DA	63DA	75DA	75DA	115DA	115DA	115DA
WT.	10.3	12.3	17.3	24.3	31.3	53.6	72.6	87.6	135.6

A	1/2"	3/4"	1"	1-1/4"	1-1/2"	2"	2-1/2"	3"	4"
B	5.50	6.30	7.11	7.74	9.03	10.49	11.48	13.95	14.74
C	2.80	3.17	3.72	3.72	4.84	5.39	5.83	7.36	7.36
D	2.99	3.29	3.64	3.99	4.33	4.98	5.91	6.01	7.26
E	5.98	6.57	7.28	7.97	8.66	9.96	11.81	12.01	14.54
F	1.61	1.77	2.07	2.07	2.68	2.87	3.15	3.94	3.94
G	5.49	6.38	8.15	8.15	10.69	12.91	14.41	20.55	20.55
ACT.	52SR	63SR	75SR	75SR	100SR	115SR	125SR	160SR	160SR
WT.	10.7	14.0	22.0	29.1	43.5	70.5	74.5	124.8	173.8

ELECTRIC ACTUATORS

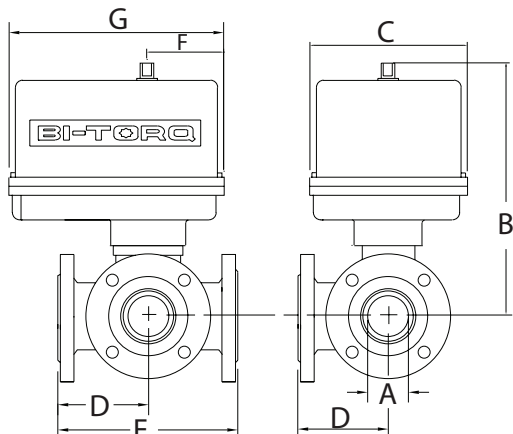

A	1/2"	3/4"	1"	1-1/4"	1-1/2"	2"	2-1/2"	3"	4"
B	6.85	8.22	8.38	9.01	11.46*	12.13*	15.65**	16.37**	21.79**
C	4.00	4.25	4.25	4.25	7.00	7.00	7.00	7.00	10.00
D	2.99	3.29	3.64	3.99	4.33	4.98	5.91	6.01	7.26
E	5.98	6.57	7.28	7.97	8.66	9.96	11.81	12.01	14.54
F	2.31	2.43	2.43	2.43	2.38	2.38	2.38	2.38	3.75
G	5.63	6.88	6.88	6.88	7.00	7.00	7.00	7.00	10.00
ACT.	100E	200E	200E	300E	400E	675E	1000E	1500E	2000E
WT.	13.0	17.0	22.0	29.0	42.0	61.0	73.0	89.0	155.0

*includes de clutchable manual override and handwheel

**includes de clutchable manual override, handwheel and mounting kit

ALL ELECTRIC ACTUATOR DIMENSIONS ARE FOR NEMA 4 ENCLOSURES. FOR NEMA 7 ENCLOSURE DIMENSIONS, PLEASE CONSULT OUR SALES STAFF.



IS-3WF SERIES 3-WAY FLANGED SS VALVES

PART #	NAME	MATERIAL	QTY
1	END CAP	CF8M	3
2	BODY	CF8M	1
3	BALL AND STEM	316SS	1
4	BUSHING	TFE	1
5	BALL SEAT	RTFE THRU 2"; TFE 2-1/2" THRU 4"	4
6	BODY SEAL	TFE	4
7	O-RING	VITON	1
8	STEM PACKING	TFE	1
9	PACKING GLAND	304SS	1
10	BELLEVILLE WASHER	301SS	2
11	GLAND NUT	304SS	1
12	HANDLE NUT	304SS	1
13	STOP PIN	304SS	1
14	HANDLE BOLT	304SS	1
15	HANDLE	304SS	1
16	BLIND CAP	CF8M	1
17, 18, 19	BOLTS AND NUTS	304SS	8
20	BONNET	CF8M	1
21	GASKET	TFE	1

VALVE FEATURES

- 3-Way full port stainless steel valves 1/2" through 4"
- Ideal for mixing, food and chem applications
- RTFE[®] seats through 2"; TFE 2-1/2" - 4"
- ANSI 150# Flanged
- 4-seat design for high cycle automation
- Self-adjusting stem packing with belleville washers

TEMPERATURE RATING

-40° F to +400° F
Steam rated to 120 PSI max

ACTUATOR FEATURES

PNEUMATIC ACTUATORS

- Rack and pinion design
- Spring return or double acting
- open and closed adjustment stops
- true NAMUR accessory mounting
- visual indicator

ELECTRIC ACTUATORS

- 120VAC, 220VAC, 24VAC, 12VDC, 24VDC
- NEMA 4 and NEMA 7 enclosures
- Manual override
- visual indicator

NOTE: Maximum temperature rating for standard actuators is 150° F (electric) and 180° (pneumatic). Special seals or heat extensions are available for high temperature service.

For more information on BI-TORQ[®] actuators, please refer to brochures PN-2007 and EL-2008 or www.bitorq.com

NOTE: not suitable for vacuum service

SEE PAGE 31 FOR AVAILABLE FLOW PATTERNS

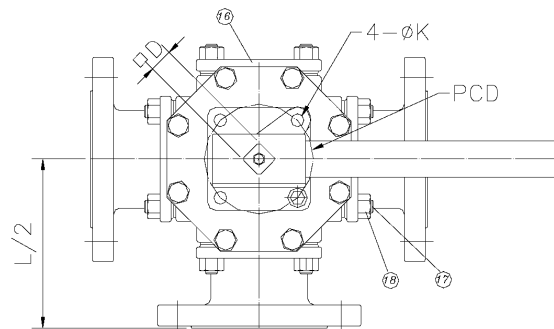
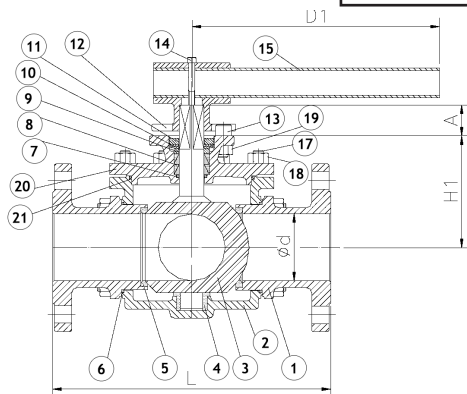

DIMENSIONAL DATA

SIZE	ISO 5211	d	L	L2	H1	A	D1	K	D	WT.
1/2"	F03-F04	0.50	5.98	2.99	1.97	0.30	5.71	0.24	0.354	8
3/4"	F04-F05	0.75	6.57	3.29	2.34	0.37	6.50	0.24	0.433	10
1"	F04-F05	1.00	7.28	3.64	2.50	0.43	7.68	0.31	0.433	15
1-1/4"	F05-F07	1.25	7.97	3.98	3.13	0.61	8.12	0.31	0.551	22
1-1/2"	F05-F07	1.50	8.66	4.33	3.46	0.65	9.84	0.39	0.551	29
2"	F07-F10	2.00	9.96	4.98	4.13	0.67	12.20	0.39	0.669	48
2-1/2"	F10	2.44	11.81	5.91	4.65	0.98	19.69	0.43	0.866	55
3"	F10	2.99	12.01	6.00	5.37	0.98	25.59	0.43	0.866	71
4"	F10	3.78	14.51	7.25	6.16	0.98	25.59	0.43	0.866	118