

SERIES 20 SS LUG STYLE KNIFE GATE VALVE

The SERIES 20 knife gate is a uni-directional all stainless steel lug style valve designed for industrial service applications. The design of the valve allows for a tight shutoff in services with solids in suspension. Industries served include:

- Pulp and Paper
- Chemical Plants
- Food and Beverage
- Mining
- Wastewater treatment
- Bulk Handling

Series 20

Applications	General Service (solid loaded fluids such as pulp and paper, wastewater and material solids)
Sizes	2" to 24" (DN50 to DN600)
Working Pressure	2"-24": 150PSI
Flange Drilling	ANSI 150 B16.5 PN10

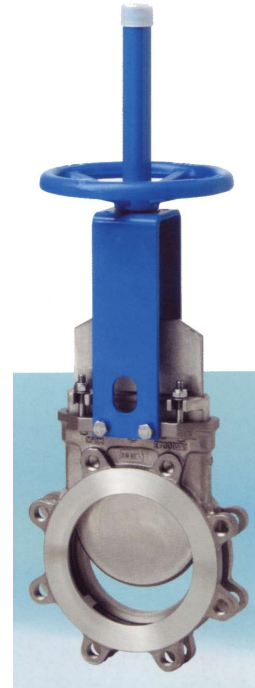

The SERIES 20 knife gate valve is available with handwheel operator, gear operator, pneumatic cylinder or multi-turn electric actuator.

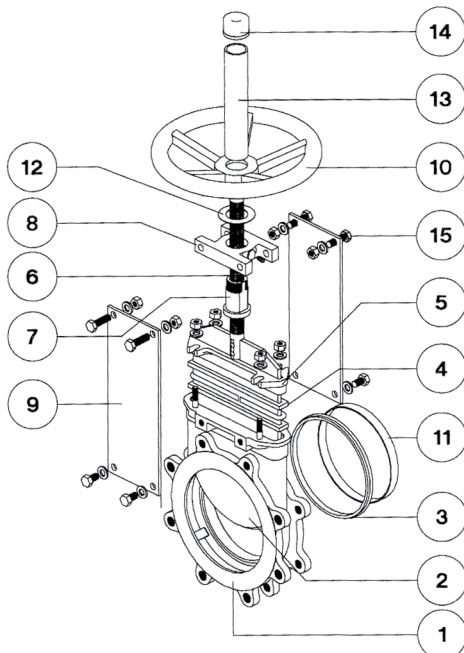

PART #	DESCRIPTION	MATERIAL
1	BODY	CF8M SS
2	GATE	AISI 316
3	SEAT	EPDM, BUNA-N, TFE OR METAL
4	PACKING	BRAIDED PTFE
5	GLAND FOLLOWER	CF8M SS
6	STEM	AISI 303
7	STEM NUT	BRONZE
8	YOKE	CARBON STEEL (2"-6") CAST IRON (8"-40")
9	SUPPORT PLATES	EPOXY COATED CARBON STEEL
10	HANDWHEEL	CAST IRON (2"-40")
11	SEAT RETAINER RING	AISI 316
12	THRUST WASHER	BRONZE
13	STEM PROTECTOR	EPOXY COATED CARBON STEEL
14	CAP	PLASTIC