

API 607 FIRE SAFE FLANGED BALL VALVE



PRESSURE RATING
Class 150 flanged
TEMPERATURE RATING
+450° F Maximum
+366° F Steam Maximum

VALVE FEATURES

- Full port stainless steel ball valve
- 1/2" through 4"
- Class 150# flanged designed to ANSI B16.34
- API607 fire safe approved
- ISO mounting pad for easy automation
- Self-adjusting stem packing
- DIN 50049-3.1B certificate

BILL OF MATERIALS

PART #	NAME	MATERIAL	QTY
1	BODY	ASTM A351 GR CF8M	1
2	ENDS	ASTM A351 GR CF8M	2
3	BALL	ASTM A351 GR CF8M	1
4	SEAT	PTFE	2
5	BODY SEAL	SS304 SPIRAL WOUND	2
6	STEM SEAL	GRAPHOIL	1
7	STEM PACKING	GRAPHOIL	1
8	THRUST WASHER	50% PTFE + 50% SS POWDER	1
9	GLAND	304SS	1
10	BELLEVILLE WASHER	304SS	2
11	LOCK WASHER	304SS	1
12	STEM NUT	304SS	1
13	HANDLE	304SS	1

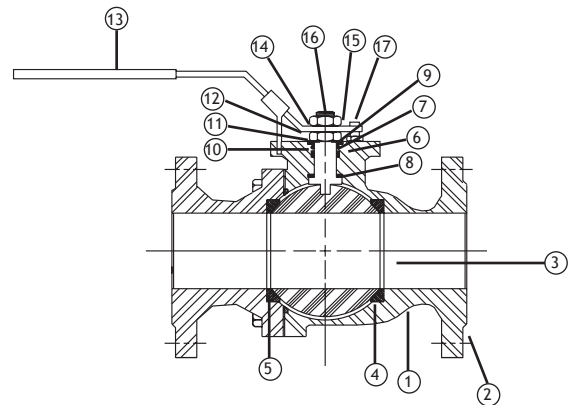
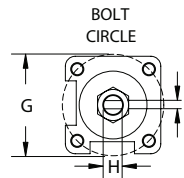
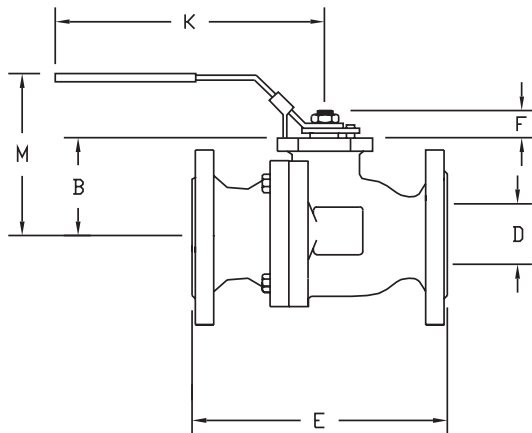

DIMENSIONAL DATA

SIZE	ISO 5211	B	D	E	F	G	H	I	K	M	CV	TORQUE	WEIGHT (LBS.)
1/2"	F04	1.51	0.59	4.25	0.24	1.42	0.248	0.472	5.90	3.53	15	88	4
3/4"	F04	1.63	0.78	4.62	0.24	1.42	0.248	0.472	5.90	3.88	40	106	6
1"	F05	1.96	0.98	5.00	0.31	1.97	0.315	0.511	7.08	4.25	70	132	8
1-1/4"	F05	1.97	1.25	5.50	0.37	1.97	0.315	0.511	7.08	4.62	130	256	12
1-1/2"	F07	2.61	1.57	6.50	0.37	2.76	0.374	0.525	8.26	5.00	240	354	16
2"	F07	2.95	1.96	7.00	0.37	2.76	0.374	0.525	8.26	6.00	400	424	21
2-1/2"	F07	3.52	2.55	7.50	0.66	2.76	0.669	1.140	10.23	7.00	700	585	38
3"	F10	4.23	3.14	8.00	0.66	4.02	0.669	1.140	10.23	7.50	980	982	46
4"	F10	4.84	3.93	9.00	0.66	4.02	0.669	1.140	12.20	9.00	1700	1239	73