

STAINLESS STEEL SANITARY CLAMP END BALL VALVE



PRESSURE RATING
1000PSI
TEMPERATURE RATING
+450 ° F Maximum CWP
366 ° F Steam Maximum

VALVE FEATURES

- Full port SS valve
- 1/2" through 4"
- 240 grit bore polish
- cavity filled TFE seats to prevent product entrapment
- swing-out 3-piece design for easy maintenance
- polished clamp end to meet ISO 5211 mounting pad for direct mount actuation (1/2"-2")

BILL OF MATERIALS

PART #	NAME	MATERIAL	QTY
1	END CAP	ASTM A351 GR CF8M	2
2	BODY SEAL	TFE	2
3	BALL	ASTM A351 316SS	1
4	BODY	ASTM A351 316SS	1
5	BALL SEAT	TFE	2
6	SPRING WASHER	304SS	1
7	GLAND NUT	304SS	1
8	STEM SEAL	TFE	1
9	O-RING	VITON	1
10	STEM PACKING	TFE	1
11	FOLLOWER	304SS	1
12	BELLEVILLE SPRING WASHERS	301SS	4
13	STEM NUT	304SS	1
14	STEM	316SS	1
15	BODY BOLT	304SS	4
16	HANDLE	304SS	1

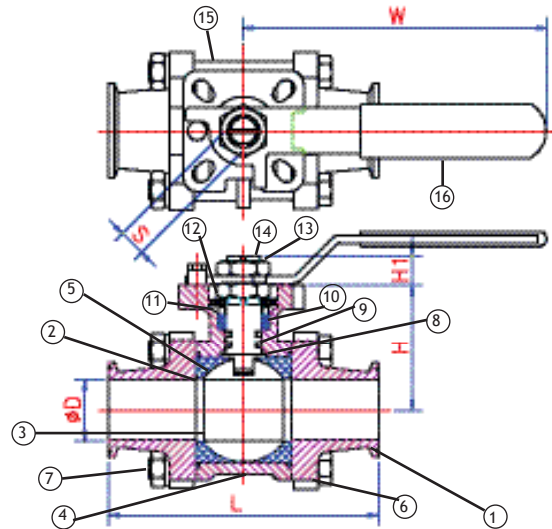
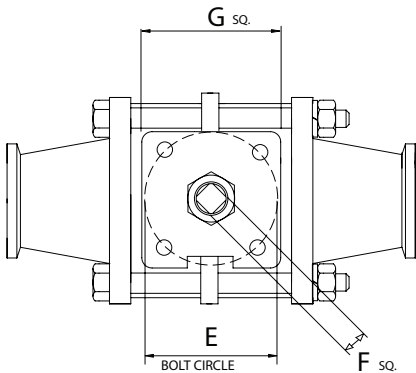

DIMENSIONAL DATA

SIZE	ISO 5211	D	E	F	G	H	H1	L	W	CV	PSI	WT.	TORQUE
1/2"	F03-F04	0.374	1.42/1.65	0.354	1.46	1.693	0.354	3.504	4.763	14	1000	1.4	35
3/4"	F03-F04	0.626	1.42/1.65	0.354	1.46	1.830	0.354	3.976	4.763	45	1000	2.0	44
1"	F04-F05	0.874	1.65/1.97	0.443	1.87	1.980	0.443	4.488	5.945	81	1000	2.9	61
1-1/2"	F05-F07	1.358	1.97/2.76	0.551	2.20	2.657	0.551	5.512	7.008	215	1000	5.7	174
2"	F05-F07	1.870	1.97/2.76	0.551	2.20	2.972	0.551	6.141	7.008	410	1000	9.0	226
2-1/2"	F07-F10	2.374	2.76/4.02	0.669	3.15	3.740	0.669	7.756	10.433	618	1000	19.3	477
3"	F07-F10	2.874	2.76/4.02	0.669	3.15	4.134	0.669	9.016	10.433	940	1000	31.2	695
4"	F10-F12	3.835	4.02/4.92	0.869	4.26	4.961	0.869	9.567	11.417	1840	1000	43.7	851