

**3-PIECE SS BALL VALVE FOR MANUAL OPERATION**



**PRESSURE RATING**  
1000 PSI  
**TEMPERATURE RATING**  
+450° F Maximum CWP  
+366° F Steam Maximum

- VALVE FEATURES**
- Full port stainless steel 3-piece ball valve
  - 1/4" through 4"
  - Blow-out proof stem design
  - ISO 5211 mounting pad for 3-piece ball valve
  - Self-adjusting stem packing
  - NPT, socket or butt weld
  - Optional padlock device

BILL OF MATERIALS			
PART #	NAME	MATERIAL	QTY
1	BODY	ASTM A351 GR CF8M	1
2	ENDS	ASTM A351 GR CF8M	2
3	BALL	ASTM A351 GR CF8M	1
4	STEM	ASTM A276 GR 316	1
5	SEAT	RTFE	2
6	PACKING	TFE	1
7	GLAND	SS304	1
8	END SEALS	TFE	1
9	THRUST WASHER	TFE	1
10	HANDLE	SS304	1
11	HANDLE NUT	SS304	1
12	SPRING WASHER	SS304	1
13	BOLTS	ASTM A193 GR B8	4-6
14	BOLT NUTS	ASTM A193 GR8	4-6
15	BOLT WASHERS	SS304	4-6
16	HANDLE SLEEVE	VINYL GRIP	1
17	LOCKING PLATE	SS304	1

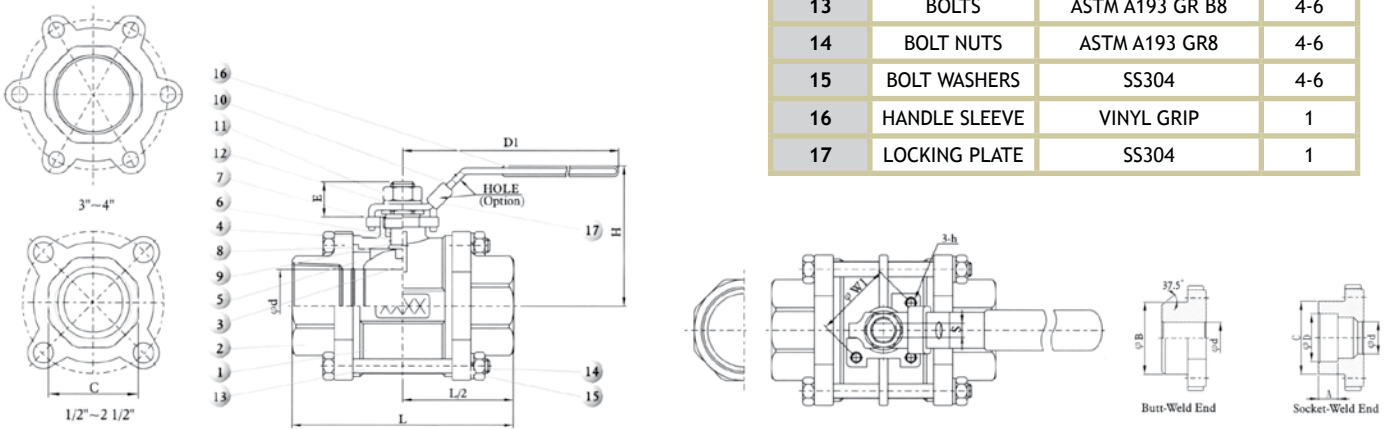

**DIMENSIONAL DATA**

SIZE	ISO 5211	A	B	C	D	E	d	L	D1	H	S	W1	h	CV	WEIGHT (LBS.)
1/4"	F04	0.39	0.71	0.90	0.56	0.61	0.43	2.56	4.06	2.13	0.22	1.42	M5	16	1.06
3/8"	F04	0.39	0.71	0.90	0.69	0.61	0.49	2.56	4.06	2.13	0.22	1.42	M5	16	1.06
1/2"	F04	0.39	0.89	1.06	0.85	0.61	0.59	2.80	4.06	2.24	0.22	1.42	M5	26	1.28
3/4"	F04	0.51	1.11	1.36	1.07	0.77	0.79	3.35	5.00	2.64	0.24	1.42	M5	55	2.02
1"	F04	0.51	1.38	1.56	1.33	0.77	1.00	3.74	5.00	2.76	0.24	1.42	M5	110	2.62
1-1/4"	F05	0.51	1.74	1.93	1.68	1.00	1.26	4.37	6.02	3.59	0.37	1.97	M6	180	4.56
1-1/2"	F05	0.51	1.97	2.20	1.92	1.04	1.57	4.76	6.02	3.74	0.37	1.97	M6	270	6.06
2"	F05	0.63	2.38	2.68	2.41	1.00	2.00	5.51	7.60	4.02	0.37	1.97	M6	500	8.96
2-1/2"	F07	0.63	3.06	3.46	2.91	1.56	2.56	6.81	10.98	4.76	0.47	2.76	M8	800	17.89
3"	F10	0.63	3.51	4.13	3.54	1.48	3.15	7.56	10.98	5.08	0.47	4.02	M10	1150	28.03
4"	F10	0.75	4.50	5.10	4.55	1.95	3.94	8.86	13.19	6.84	0.63	4.02	M10	2120	46.52