

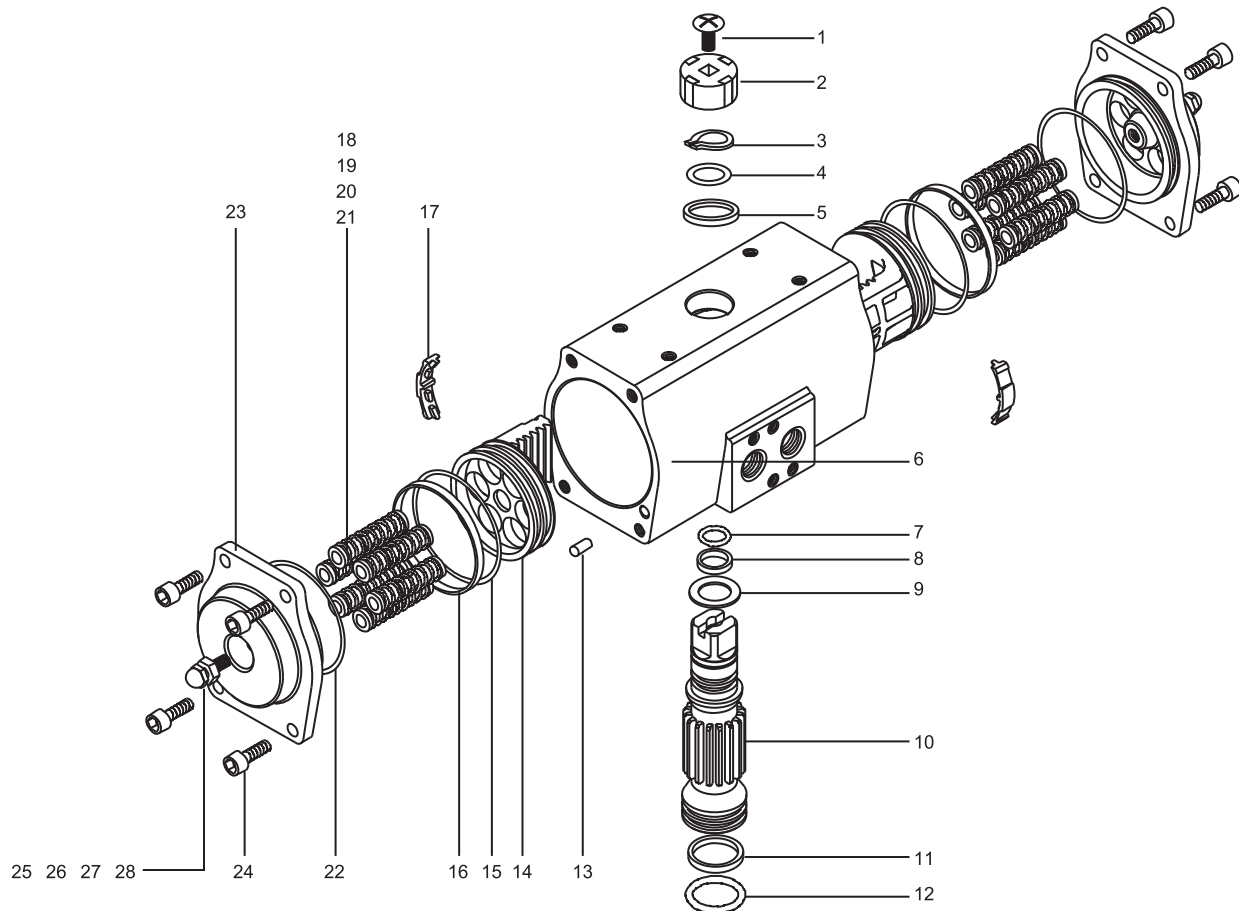

AL-SERIES PNEUMATIC ACTUATOR PARTS LIST



PART NUMBER	DESCRIPTION	MATERIAL	QTY.
1	INDICATOR SCREW	STAINLESS STEEL	1
2	INDICATOR	PLASTIC	1
3	SNAP RING	STAINLESS STEEL	1
4	WASHER	STAINLESS STEEL	1
5	OUTSIDE WASHER	POLYOXYMETHYLENE	1
6	BODY	ALUMINUM ALLOY	1
7	O-RING (top)*	NBR*	1
8	BEARING (top)*	POLYOXYMETHYLENE*	1
9	INSIDE WASHER	POLYOXYMETHYLENE	1
10	PINION	ALLOY STEEL	1
11	BEARING (bottom)*	POLYOXYMETHYLENE*	1
12	O-RING (bottom)*	NBR*	1
13	PLUG	NBR	2
14	PISTON	DIE CAST ALUMINUM	2
15	PISTON O-RING*	NBR*	2

PART NUMBER	DESCRIPTION	MATERIAL	QTY.
16	PISTON BEARING*	POLYOXYMETHYLENE*	2
17	PISTON GUIDE*	NYLON 66*	2
18	CARTRIDGE SPRING	STEEL	12
19	SPRING RETAINER (L)	NYLON 66	6
20	SPRING RETAINER (R)	NYLON 66	6
21	RETAINER CONNECTOR	BRASS	12
22	END CAP O-RING*	NBR*	2
23	END CAP	DIE CAST ALUMINUM	2
24	END CAP STOP SCREW	STAINLESS STEEL	8
25	ADJUSTMENT SCREW	STAINLESS STEEL	2
26	ADJUSTMENT NUT	STAINLESS STEEL	2
27	ADJUSTMENT WASHER	STAINLESS STEEL	2
28	ADJUSTMENT O-RING*	NBR*	2

*Parts subject to wear

MAINTENANCE & OPERATING INSTRUCTIONS

BI-TORQ® ACTUATOR OPERATION

NOTE: For optimal operation, BI-TORQ actuators should be run with a supply of clean, lubricated air.

SPRING RETURN ACTUATORS

Air to PORT 2 (the right hand port) causes the actuator to turn CCW. Loss of air to PORT 2 causes air to exhaust and the actuator turns CW. This is the FAIL CLOSE operation.

DOUBLE ACTING ACTUATORS

Air to PORT 2 (the right hand port) causes the actuator to turn CCW. Air to PORT 1 (the left hand port) causes the actuator to turn CW.

DISASSEMBLING STANDARD ACTUATORS

IMPORTANT: Before beginning disassembly, ensure that the air supply to the actuator has been disconnected, all accessories have been removed and that the actuator has been dismantled from the valve.

1. Loosen the end cap fasteners (22) with a wrench (size varies depending on actuator model). On the spring return actuator, alternate 3 to 5 turns on each fastener until the springs are completely decompressed. Use caution in removing the cap since the springs are under load until the fasteners are fully extended.
2. Remove the pinion snap ring (10) with a lock ring tool. The indicator (7) may now be removed.
3. Turn the pinion shaft (2) CCW until the pistons are at the full end of travel. Disengage the pistons (11) from the pinion. (NOTE: Low pressure air--3 to 5 P.S.I. MAXIMUM--might be required to force the pistons completely from the body.) Note the position of the pistons before removing them from the actuator body. The part numbers of the pistons are located on the side and should be right-side up on an actuator with a standard orientation.
4. Remove the pinion through the bottom of the actuator. The actuator is now completely disassembled. All replacement parts may now be put in. BI-TORQ recommends that all wear parts (3, 4, 5, 6, 12, 13, 14) be replaced before reassembly.

REASSEMBLING STANDARD ACTUATORS

IMPORTANT: Be sure that the actuator surfaces are free of grit and scratches before reassembling.

1. Apply a light film of grease to all o-rings and the pinion before replacing.
2. Put the pinion (2) back through the actuator with the flats of the pinion shaft running parallel with the body.
3. When reassembling the actuator, make sure that the piston racks are square to the actuator body and returned to their original orientation. (NOTE: The normal operation of all BI-TORQ actuators is FAIL CLOSED. If you want to change the orientation to FAIL OPEN, rotate the racks 180° to create a reverse operation.
4. When replacing springs in a spring return actuator, ensure that the springs are replaced in their identical position in the end cap from which they were removed. (NOTE: In some circumstances, you might want to change the standard 80 pound spring set to fit your application and available air pressure. Changing the spring sets on BI-TORQ actuators requires no special tools. Please refer to the spring combination torque chart in our catalog for the inner and outer spring combinations that will allow you to operate with the spring set that you desire.
4. Seal the end caps with a petroleum lubricant and bolt to actuator body.
5. Check the seal of the actuator by covering seal areas (pinion, end caps) with soapy water and using low pressure air to the actuator to ensure that no bubbles are produced.