



## INSTALLATION & MAINTENANCE FOR HT-SERIES

### I. OVERVIEW OF THERMAL SHUT-OFF VALVES

BI-TORQ Valve Automation<sup>®</sup> thermal shut-off valves are designed for flow shutoff protection in piping systems handling flammable gasses, liquids, solvents, toxic fluids, or any other potentially dangerous media. These fire control valves terminate flow in the event of fire, aiding in reducing fire intensity. In the event of fire, the fusible link separates, allowing the top mounted spring pack to drive an API 607 fire safe rated valve into a closed position. Fusible links are available in a range of temperature settings. The thermal shut-off valves also are available in a fail open position, ideal for a fire suppression system in the event of a fire.

The thermal shut-off valves you have received have been assembled and tested at our factory with attention to safety in mind. BI-TORQ Valve Automation<sup>®</sup> uses high quality materials and tested engineering to ensure that this product will operate safely and reliably. Carefully read all instructions before handling in order to avoid injury to the operator or damage to the product.

NOTE: Please refer to the attached assembly drawing FL-HD-0600 for parts identification and complete parts list.

### II. GENERAL SAFETY INSTRUCTIONS

**WARNING:** Use extreme caution in handling the assembly because the spring pack is under full tension at all times.

**NOTE:** *Ball valves are shipped in the OPEN and ARMED position; butterfly valves are shipped in the CLOSED and ARMED position.*

**BALL VALVES ONLY:** For shipping purposes, a safety link (#9) has been installed. This part is PAINTED RED. (see illustration 2.1)

**IMPORTANT: THE SAFETY LINK MUST BE REMOVED AND REPLACED WITH THE FUSIBLE LINK(S) AFTER THE VALVE HAS BEEN PUT IN LINE. IF SAFETY LINKS ARE NOT REMOVED, THE ASSEMBLY WILL NOT OPERATE CORRECTLY.**

The unit must be installed in a location with carefully maintained ambient temperatures. Installing the link in locations where high temperature fluctuations are possible (such as direct sunlight) is not recommended. Exposure to high ambient temperatures can cause the fusible links to break prematurely. (See chart 1 for link temperature ratings.)

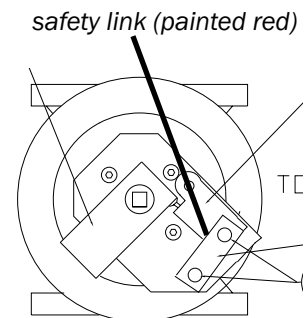

illustration 2.1



# INSTALLATION & MAINTENANCE FOR HT-SERIES

## III. INSTALLING FUSIBLE LINKS ON THE HT SERIES ASSEMBLY

### FOR ARMED ASSEMBLY USING BALL VALVES

**IMPORTANT: ASSEMBLIES WITH BALL VALVES ARE SHIPPED IN OPEN POSITION WITH RED SAFETY LINK(S) INSTALLED. UNITS ARE PROPERLY ARMED AND READY FOR INSTALLATION WHEN FUSIBLE LINKS ARE INSTALLED AND DECLUTCH GEAR IS DISENGAGED.**

**NOTE: INSTALL VALVE IN PIPELINE BEFORE PROCEEDING!**

REQUIRED TOOLS: NONE

1. Engage declutchable manual override gear with declutch mechanism (#2). (Refer to drawing FL-HT-0600-1.4 for engaged/disengaged positions on declutch gear.)
2. Turn the declutch gear handwheel toward the open position (CCW) to relieve tension on the red safety link(s) (#9) and then remove link. **CAUTION:** Keep declutch in engaged position while replacing safety links.
3. Secure fusible link(s) to retaining arm (#8) studs with 5/16" x 18 nuts until link is held firmly in position. **CAUTION: HAND-TIGHTEN ONLY!** Do not tighten nuts. Tightening will stress the links and could result in improper functioning.
4. Disengage declutch by turning handwheel clockwise (CW) until the declutch lever can easily move into disengaged position. **DO NOT FORCE LEVER INTO POSITION.**



illustration 3.1

### FOR ARMED ASSEMBLY USING BUTTERFLY VALVES

**IMPORTANT: ASSEMBLIES WITH HIGH PERFORMANCE BUTTERFLY VALVES ARE SHIPPED IN THE CLOSED POSITION AND MUST BE MOVED TO THE OPEN POSITION AND ARMED WITH FUSIBLE LINKS AFTER INSTALLATION.**

**NOTE: INSTALL VALVE IN PIPELINE BEFORE PROCEEDING!**

REQUIRED TOOLS: NONE

1. The declutchable manual override gear is in the ENGAGED position. **IMPORTANT:** Leave the declutch in the engaged position while following the steps below. (Refer to drawing FL-HT-0600-1.4 for engaged/disengaged positions on declutch gear.)
2. Remove the nuts holding the red safety link (#9). **CAUTION:** Keep declutch in engaged position while replacing safety links and fusible links.
3. While leaving the links off and keeping the declutch engaged, turn the declutch handwheel counter-clockwise (CCW) until the valve is fully open. (Refer to drawing FL-HT-0600-1.4 for engaged/disengaged positions on declutch gear.)
4. Move pivot arm (#11) into armed position (see drawing FL-HT-0600-1.1 and 1.2).
5. Place fusible links onto #8 link holding studs. **IMPORTANT: DO NOT REINSTALL SAFETY LINK.**
6. SLOWLY turn declutch handwheel clockwise (CW) toward the closed position until spring tension is held by fuses.
7. Disengage declutch by turning handwheel EITHER slightly clockwise (CW) or counter-clockwise (CCW) if necessary until the declutch handwheels can easily move into disengaged position. **DO NOT FORCE handwheels INTO POSITION.**
8. Unit is now armed.

**IMPORTANT: THE UNIT IS NOT ARMED UNTIL THE GEAR HAS BEEN DISENGAGED AFTER INSTALLATION OF LINKS. IF THE GEAR IS LEFT IN THE ENGAGED POSITION THE VALVE WILL NOT SPRING CLOSE.**



# INSTALLATION & MAINTENANCE FOR HT-SERIES

## IV. OPERATION

The valve may be operated closed-open in the normal manner using the declutchable gear handwheel **ONLY** upon removal of the fusible links.

**IMPORTANT: FAILURE TO REMOVE FUSIBLE LINKS PRIOR TO OPERATING VALVE WILL DAMAGE THE ASSEMBLY.**

In order to remove fusible links, **REVERSE** installation instructions listed in section III. After removing fusible links, store in a safe place. **DO NOT** re-install red safety link. To engage the declutchable gear operator for manual operation, refer to section VI (operating declutchable manual override gear). The gear lever must always be returned to the DISENGAGED position after manually operating the valve and the links must be put back into place.

**CAUTION: Failure to return the gear to the disengaged position will lock the gear and valve into position, and the fusible link assembly will not function properly.**

**IMPORTANT: The fusible links must be returned to their original position after manual operation.**

## V. MAINTENANCE

**IMPORTANT: The fusible link manufacturer recommends annual replacement of link(s) as part of a regular maintenance schedule. Contact your local distributor or BI-TORQ® Valve Automation for replacement links. Order by part number or temperature rating on old link.**

Replacement valve seats and seals subject to normal wear are available from your local distributor or BI-TORQ® Valve Automation.

The spring case and declutchable gear are lifetime lubricated and do not require maintenance. Disassembly of the spring case or gear will void any written or verbal warranties.

**WARNING: THE SPRING CASE CLOCKSING IS ALWAYS UNDER PRESSURE. DO NOT DISASSEMBLE SPRING PACK UNDER ANY CIRCUMSTANCES. DISASSEMBLY OF THE SPRING PACK COULD RESULT IN SERIOUS INJURY OR DEATH.**

FL-1: FOR SIZE 10 SPRING		
LINK PART NUMBER	LINK YIELD TEMPERATURE	MAXIMUM AMBIENT TEMPERATURE
FL-1-165	165° F/74° C	135° F/57° C
FL-1-212	212° F/100° C	185° F/82° C
FL-1-286	286° F/138° C	253° F/123° C
FL-1-360	360° F/182° C	330° F/166° C

K-LINK: FOR SIZE 12 SPRING		
LINK PART NUMBER	LINK YIELD TEMPERATURE	MAXIMUM AMBIENT TEMPERATURE
110135	135° F/57° C	104° F/41° C
314165	165° F/74° C	135° F/57° C
110212	212° F/100° C	185° F/82° C
110280	280° F/138° C	253° F/123° C
110360	360° F/182° C	330° F/166° C

*Please consult factory for special order links*



**FUSIBLE LINK  
IOM**

FL-HT-0600-1.1

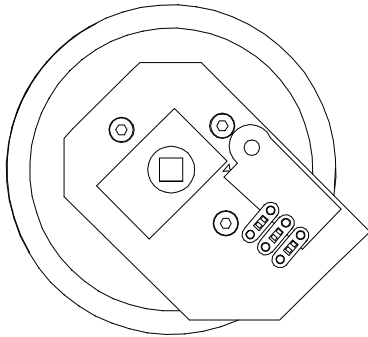

TOP VIEW ARMED

FL-HT-0600-1.2

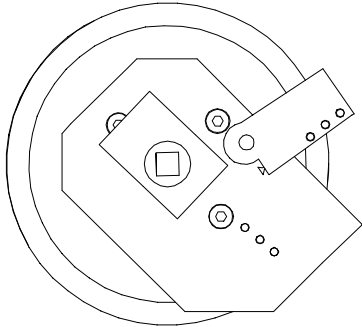

TOP VIEW DISARMED

FL-HT-0600-1.4

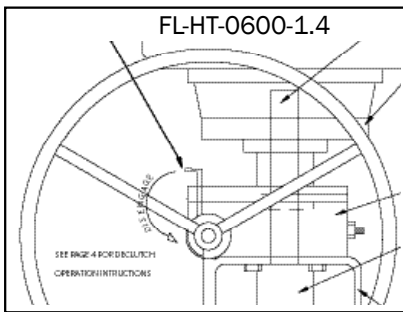

**IMPORTANT: IMPROPER INSTALLATION OR ARMING OF FUSIBLE LINK ASSEMBLIES WILL VOID WARRANTY, AS WILL DISASSEMBLY OF THE PRODUCT WITHOUT PRIOR APPROVAL FROM FACTORY.**

SPRING PACK	# OF LINKS PER UNIT	LINK TYPE
109-020	6	FL-1
129-020	6	K-LINK

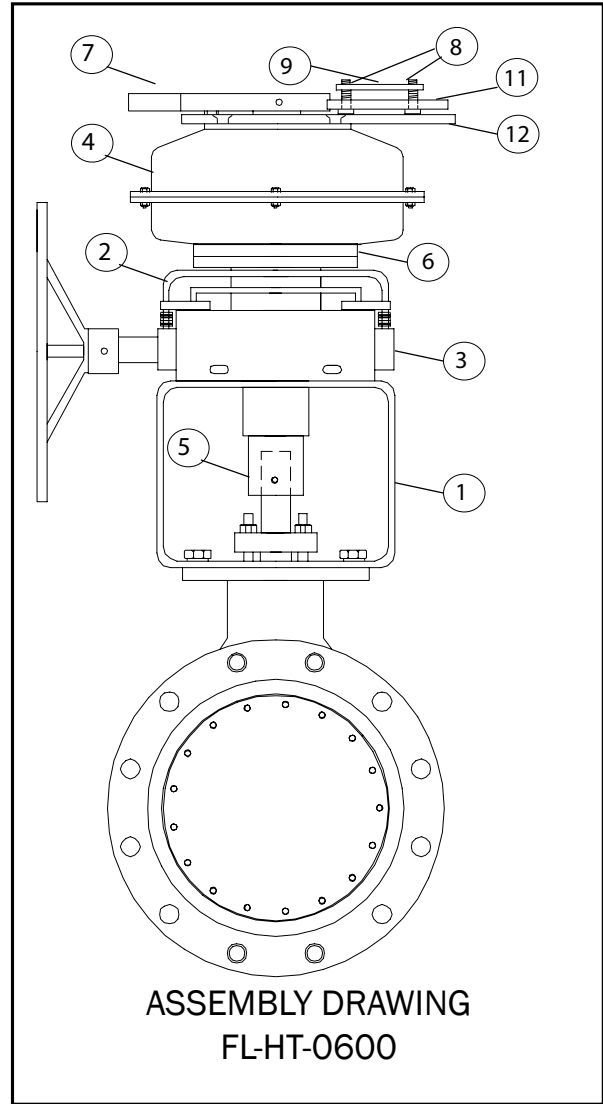

1	mounting bracket	7	spring pack keeper lever
2	declutch lever	8	link holding studs
3	declutchable gear operator	9	fusible links (NOTE: see chart on left for link quantities per spring pack size)
4	spring pack (109, or 129)	10	open position adjustment stops
5	valve adapter	11	pivot arm
6	spring pack mounting plate (129 spring pack only)	12	mounting plate for fusible link



# INSTALLATION & MAINTENANCE FOR HT-SERIES

## VI. OPERATING THE DECLUTCHABLE MANUAL OVERRIDE GEAR

**IMPORTANT:** Make sure that the fusible links have been removed before attempting to operate the valve with the declutchable manual override.

Use the following instructions to ENGAGE the declutchable manual override.

1. Using one hand, grab the override engagement handle, squeezing the bottom handle and top handle together.
2. With the handles still squeezed together, rotate the handle from its declutched position upward toward the spring pack mounting flange until the handle locking tabs are inline with their locking positions.  
**NOTE:** In some cases the override gear teeth will not mesh correctly when rotating the handle upward. If this occurs, rotate the override handwheel slightly to mesh the gears and then rotate the declutch handle upward.
3. Once the override handle is in its locked position, the override is ready to be used. Clockwise rotation of the override handwheel will produce clockwise rotation of the override output and valve. Conversely, counterclockwise rotation of the handwheel will produce counterclockwise rotation of the override output, and valve.

Use the following instructions to **DISENGAGE** the declutchable manual override.

Note: When the assembly is rearmed with the fusible links back in place, the the manual override must be returned to its declutched position. Reversing the procedure above will return the override to the declutched position. Make sure that the handle locking tabs are inserted into their locking position on the override housing.

Leaving the declutch engaged will prohibit the spring return unit from cycling the valve to the closed position when the fusible links yield. Leaving the unit in the engaged position will prevent the unit from operating correctly, may cause damage to the override as well as drivers linkages, etc. and void the override warranty.

**IMPORTANT:** The fusible links will have to be reinstalled and the declutch disengaged before the assembly is properly armed.



DISENGAGED

The picture on the left shows the declutch operator in the disengaged to allow the spring pack to close the valve when the fusible links yield. As shown, the handle arrangement is pinned in the down position. The handwheel should rotate freely in either the clockwise or counterclockwise directions without affecting the valve rotation.



ENGAGED

The picture on the left shows the declutch in the “override” position, or “engaged,” for operating the valve manually. As shown, the handle arrangement is pinned in the up position for override. Rotation of the handwheel clockwise will rotate valve clockwise (generally closed direction); rotation of the handwheel counter-clockwise will rotate actuator counterclockwise (generally open).

**IMPORTANT:** FUSIBLE LINKS MUST BE REMOVED BEFORE ATTEMPTING TO OPERATE THE VALVE WITH THE DECLUTCH.